

Box Elder County - Weber County
Found Brass Cap Monument

North Quarter Corner of Sec. 23,
T. 7 N., R. 2 W., SLB&M
Found Weber Co. Brass Cap Monument

Northeast Corner of Sec. 23,
T. 7 N., R. 2 W., SLB&M
Found Weber Co. Brass Cap Monument

AS SURVEYED BOUNDARY DESCRIPTION

A PART OF THE SOUTHEAST QUARTER OF SECTION 14 AND A PART OF THE NORTHEAST QUARTER OF SECTION 23, TOWNSHIP 7 NORTH, RANGE 2 WEST OF THE SALT LAKE BASE AND MERIDIAN.

BEGINNING AT THE INTERSECTION OF THE NORTH LINE OF SAID NORTHEAST QUARTER AND THE WESTERLY RIGHT-OF-WAY LINE OF THE UNION PACIFIC RAILROAD LOCATED 1239.45 FEET NORTH 89°13'58" WEST ALONG THE NORTH LINE OF SAID NORTHEAST QUARTER FROM THE NORTHEAST CORNER OF SAID SECTION 23;

RUNNING THENCE SOUTH 25°53'52" EAST 1478.70 FEET ALONG SAID WESTERLY RIGHT-OF-WAY LINE TO AN EXISTING FENCE LINE BEING THE SOUTH LINE OF THE NORTH HALF OF SAID NORTHEAST QUARTER; THENCE NORTH 89°16'13" WEST 1318.35 FEET ALONG SAID EXISTING FENCE LINE AND SAID SOUTH LINE TO THE EASTERLY RIGHT-OF-WAY LINE OF INTERSTATE 15; THENCE NORTH 18°08'06" WEST 1765.10 FEET ALONG SAID EASTERLY RIGHT-OF-WAY LINE TO THE BOX ELDER COUNTY - WEBER COUNTY LINE; THENCE SOUTH 89°35'10" EAST 974.02 FEET ALONG SAID COUNTY LINE TO THE WESTERLY RIGHT-OF-WAY LINE OF SAID UNION PACIFIC RAILROAD; THENCE ALONG SAID WESTERLY RIGHT-OF-WAY LINE THE FOLLOWING TWO (2) COURSES: (1) SOUTH 25°53'52" EAST 395.72 FEET; AND (2) SOUTH 89°13'58" EAST 74.97 FEET TO THE POINT OF BEGINNING. CONTAINING 44.90 ACRES.

Narrative

The purpose of this survey was to establish and set the property corners of the parcels as shown and described hereon. The survey was ordered by Dana Shuler of Jones and Associates for Pleasant View City. The Box Elder County - Weber County Line was determined from ROS# 1366 which still found monuments to the west and ties to section corners as shown on said ROS. Interstate 15 was determined from UDOT Project No. 1-15-8(7)338 which fell in harmony with a found Right-of-Way Monument along the East Right-of-Way and existing fence along said Right-of-Way. The location of the Old Railroad was determined from deed calls which fall in harmony with an existing gravel road on the Abandoned Railroad Grade and an existing fence line 8.25 feet east of the Abandoned Railroad Centerline. There is an existing fence line along the South boundary which was used as best evidence of the South Line of the North Half of the Northeast Quarter. The control used to establish the property corners was the existing Weber County Survey Monumentation surrounding Section 23, T7N, R2W, SLB&M. The basis of bearing is the North line of the Northeast Quarter of said Section which bears North 89°13'58" West, Utah North, State Plane, Calculated N.A.D.83 Bearing.

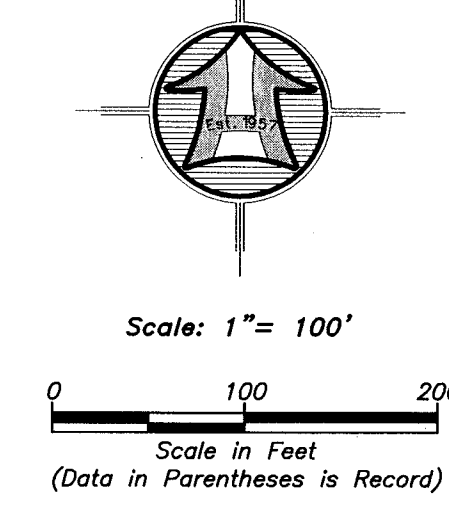

LEGEND

	Subject Property Line
	Adjoining Property Line
	County Line
	Centerline
	Railroad Tracks
	Fence Line (Wire)
	Right-of-Way Monument
	Found Survey Marker
	Set 5/8"x24" Rebar With Cap
	Section Corner

SURVEYOR'S CERTIFICATE

I, K. Greg Hansen, do hereby certify that I am a Registered Professional Land Surveyor in the State of Utah in accordance with Title 58, Chapter 22, Professional Engineers and Professional Land Surveyors Act; and by the authority of the owners, I have completed a survey of the property described and shown hereon this plat in accordance with Section 17-23-17 and have verified all measurements, and that the same has been surveyed and monuments have been located and/or placed on the ground as represented on the plat hereon.

Signed this 17th day of April, 2019.

K. Greg Hansen PLS
Utah Land Surveyor Licence No. 167819

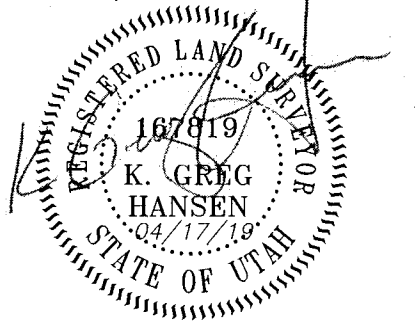

<p>HANSEN & ASSOCIATES, INC. Consulting Engineers and Land Surveyors 538 North Main Street, Brigham, Utah 84302 Visit us at www.hansen.net Logan Ogden (435) 723-3491 (801) 399-4905 (435) 752-4272 Celebrating 60 Years of Business</p>	
<p>Drawn By: RS Designed By: Checked By: Approved By: Scale: 1" = 100' Drawing File: 19-3-61\15H4.dwg JOB NUMBER: 19-3-61</p>	<p>Date: 04/16/2019</p>
<p>Property Survey for Pleasant View City ±4300 North & I-15 Pleasant View City, Weber County, Utah A Part of the Northeast Quarter of Section 23 and A Part of the Southeast Quarter of Section 14, Township 7 North, Range 2 West, S.L.B.&M.</p>	
<p>Sheet 1 of 1 Sheets</p>	<p>RECEIVED APR 17 2019 BY: 16325</p>