

East Quarter Corner of Sec. 23,
T. 6 N., R. 1 E., S.L.B.&M
Found BLM Brass Cap Monument 1966

Narrative
The purpose of this survey was to establish and set the property corners of the parcel as shown and described hereon. The survey was ordered by Joe Elwood. The control used to establish the property corners was the official plat of the MWT Subdivision recorded as Entry No. 2935117 along with the existing Weber County Survey Monumentation surrounding Section 23, T6N, R1E, S1B&M. The basis of bearing is the East line of the Southeast Quarter of said Section which bears South 0°48'16" West, Utah North, State Plane, Calculated N.A.D.83 Bearing.

AS SURVEYED BOUNDARY DESCRIPTION
A PART OF THE SOUTHEAST QUARTER OF SECTION 23, TOWNSHIP 6 NORTH, RANGE 1 EAST OF THE SALT LAKE BASE AND MERIDIAN.
BEGINNING AT THE SOUTHEAST CORNER OF SAID SECTION 23 AND RUNNING THENCE NORTH 89°40'44" WEST 36.74 FEET (NORTH 88°28'06" WEST 36.40 FEET BY RECORD) TO THE SOUTHEAST CORNER OF THE MWT SUBDIVISION RECORDED AS ENTRY NO. 2935117 IN THE WEBER COUNTY RECORDERS OFFICE; THENCE NORTH 39°56'20" WEST 1022.57 FEET (NORTH 40°44'28" WEST 1023.01 FEET BY RECORD) TO THE NORTHEAST CORNER OF SAID MWT SUBDIVISION; THENCE NORTH 07°25'08" EAST (NORTH 06°37'00" EAST BY RECORD) 185.00 FEET; THENCE NORTH 19°16'07" WEST (NORTH 20°04'15" WEST BY RECORD) 80.25 FEET; THENCE SOUTH 64°03'52" EAST 784.66 FEET (SOUTH 64°52'00" EAST 784.74 FEET BY RECORD) TO THE EAST LINE OF SAID SOUTHEAST QUARTER; THENCE SOUTH 00°48'16" WEST 700.34 FEET (SOUTH 700.44 FEET BY RECORD) ALONG SAID EAST LINE TO THE POINT OF BEGINNING. CONTAINING 8.00 ACRES.
BASIS OF BEARING IS THE EAST LINE OF SAID SOUTHEAST QUARTER WHICH BEARS SOUTH 00°48'16" WEST.

SURVEYOR'S CERTIFICATE
I, K. Greg Hansen, do hereby certify that I am a Registered Professional Land Surveyor in the State of Utah in accordance with Title 58, Chapter 22, Professional Engineers and Professional Land Surveyors Act; and by the authority of the owners, I have completed a survey of the property described and shown hereon this plat in accordance with Section 17-23-17 and have verified all measurements, and that the same has been surveyed and monuments have been located and/or Placed on the ground as represented on the plat hereon.
Signed this 13th day of May, 2019.
K. Greg Hansen PLS
Utah Land Surveyor Licence No. 167819

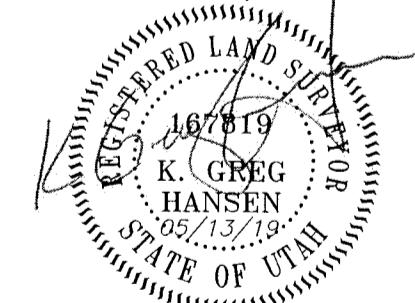

- LEGEND**
- Subject Property Line
 - - - Subdivision Boundary
 - Adjoining Property Line
 - - - Existing Gravel Road
 - - - Easements
 - - - Fence Line
 - Found rebar set by others
 - Set 5/8"x24" Rebar With Cap
 - Section Corner

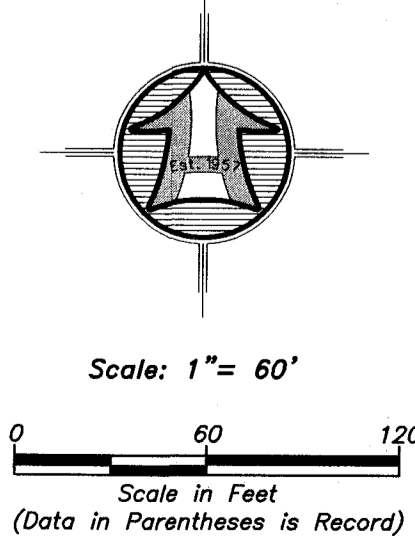

HANSEN & ASSOCIATES, INC. Consulting Engineers and Land Surveyors 538 North Main Street, Brigham, Utah 84302 Visit us at www.ha-inc.com Brigham City, Utah (435) 723-3491 (801) 389-4905 (435) 752-8272 Celebrating over 60 Years of Business	
	Drawn By: RS Date: 05/10/2019 Designed By: _____ Checked By: _____ Approved By: _____ Scale: 1" = 60' Drawing File: 19-3-2015.dwg JOB NUMBER: 19-3-70
Property Survey for Joe Elwood ±1650 South Tolliver Lane Weber County, Utah A Part of the Southeast Quarter of Section 23 Township 6 North, Range 1 East, S.L.B.&M.	
RECEIVED AUG 13 2019 BY: 6226	Sheet 1 of 1 Sheets