

CURVE TABLE					
CURVE #	LENGTH	RADIUS	DELTA	CHORD BEARING	CHORD LENGTH
C1	52.36	150.00	20°00'00"	N9° 08' 02"W	52.09
C2	52.20	150.00	19°56'15"	N9° 09' 55"W	51.93
C4	34.74	180.00	11°03'31"	N13° 36' 17"W	34.69
C5	41.89	120.00	20°00'00"	N9° 08' 02"W	41.68
C6	46.11	180.00	14°40'38"	S8° 28' 21"E	45.98
C7	16.72	180.00	5°19'22"	S16° 28' 21"E	16.72
C8	11.80	120.00	5°38'00"	S16° 19' 02"E	11.79

CURVE TABLE					
CURVE #	LENGTH	RADIUS	DELTA	CHORD BEARING	CHORD LENGTH
C9	29.96	120.00	14°18'15"	S6° 20' 54"E	29.88
C10	227.25	50.00	260°24'21"	S41° 04' 09"W	76.38
C11	78.49	50.00	89°56'15"	S44° 09' 55"E	70.67
C12	148.76	50.00	170°28'06"	S86° 02' 18"W	99.65
C13	14.03	10.00	80°24'21"	N48° 55' 51"W	12.91

YULISA ESTATES

LOCATED IN THE SOUTHWEST QUARTER OF SECTION 35,
TOWNSHIP 6 NORTH, RANGE 2 WEST, SALT LAKE BASE AND MERIDIAN,
WEST HAVEN CITY, WEBER COUNTY, UTAH
AUGUST 2019

VICINITY MAP
NOT TO SCALE

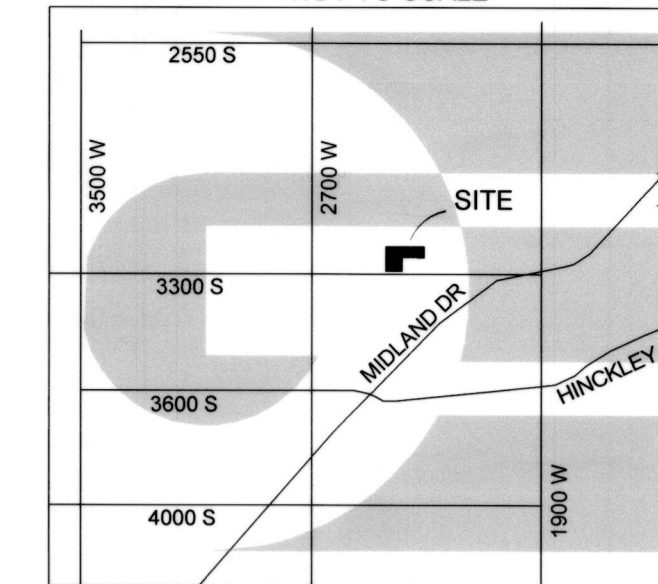

BOUNDARY DESCRIPTION

A PART OF THE SOUTHWEST QUARTER OF SECTION 35, TOWNSHIP 6 NORTH, RANGE 2 WEST OF THE SALT LAKE BASE AND MERIDIAN, MORE PARTICULARLY DESCRIBED AS FOLLOWS: BEGINNING AT A POINT ON THE NORTHERLY RIGHT-OF-WAY LINE OF 3300 SOUTH STREET BEING LOCATED NORTH 89°07'54" WEST 465.94 FEET ALONG THE SOUTH LINE OF SAID SOUTHWEST QUARTER AND NORTH 0°00'00" EAST 40.00 FEET FROM THE SOUTH QUARTER CORNER OF SAID SECTION; RUNNING THENCE ALONG SAID RIGHT-OF-WAY LINE NORTH 89°07'54" WEST 358.50 FEET; THENCE NORTH 0°48'13" EAST 529.00 FEET; THENCE SOUTH 89°08'02" EAST 808.50 FEET; THENCE SOUTH 0°48'13" WEST 242.00 FEET; THENCE NORTH 89°08'02" WEST 150.00 FEET; THENCE NORTH 0°48'13" EAST 3.40 FEET; THENCE NORTH 89°08'02" WEST 300.00 FEET; THENCE SOUTH 0°48'13" WEST 290.40 FEET TO THE POINT OF BEGINNING. CONTAINING 297,526 SQ. FT. OR 6.83 AC. MORE OR LESS.

GILBERT & BONNIE KAP FMLY TRST
150940133

FOUND
NORTH QUARTER CORNER
SEC. 35, T6N, R2W, SLB&M
W.C. 3" BRASS CAP-2018
8" BELOW ROAD-GOOD COND.

SURVEYOR'S CERTIFICATE

I, KLINT H. WHITNEY, DO HEREBY CERTIFY THAT I AM A LICENSED PROFESSIONAL LAND SURVEYOR IN THE STATE OF UTAH AND THAT I HOLD CERTIFICATE NO. 8227228 IN ACCORDANCE WITH TITLE 58, CHAPTER 22, OF THE PROFESSIONAL ENGINEERS AND LAND SURVEYORS ACT; I FURTHER CERTIFY THAT BY AUTHORITY OF THE OWNERS I HAVE COMPLETED A SURVEY OF THE PROPERTY AS SHOWN AND DESCRIBED ON THIS PLAT, AND HAVE SUBDIVIDED SAID PROPERTY INTO LOTS AND STREETS, TOGETHER WITH EASEMENTS, HEREAFTER TO BE KNOWN AS YULISA ESTATES IN ACCORDANCE WITH SECTION 17-23-17 AND HAVE VERIFIED ALL MEASUREMENTS; THAT THE REFERENCE MONUMENTS SHOWN HEREON ARE LOCATED AS INDICATED AND ARE SUFFICIENT TO RETRACE OR REESTABLISH THIS SURVEY; THAT ALL LOTS MEET THE REQUIREMENTS OF THE LAND USE CODE; AND THAT THE INFORMATION SHOWN HEREIN IS SUFFICIENT TO ACCURATELY ESTABLISH THE LATERAL BOUNDARIES OF THE HEREIN DESCRIBED TRACT OF REAL PROPERTY.

SIGNED THIS 17th DAY OF AUGUST 2019.

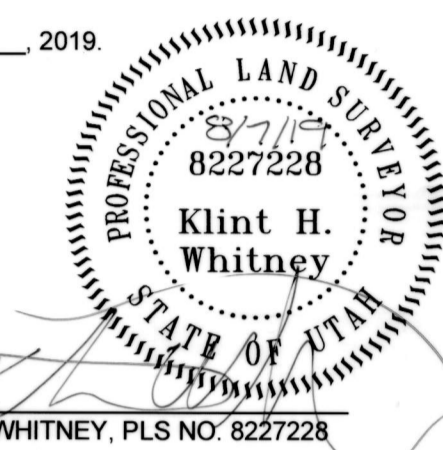

OWNER'S DEDICATION

I THE UNDERSIGNED OWNER OF THE HEREON DESCRIBED TRACT OF LAND, HEREBY SET APART AND SUBDIVIDE THE SAME INTO LOTS, PARCELS AND STREETS AS SHOWN ON THIS PLAT AND NAME SAID TRACT:

YULISA ESTATES

AND HEREBY DEDICATE, GRANT AND CONVEY TO WEST HAVEN CITY, WEBER COUNTY, UTAH, ALL THOSE PARTS OR PORTIONS OF SAID TRACT OF LAND DESIGNATED AS STREETS, THE SAME TO BE USED AS PUBLIC THOROUGHFARES FOREVER, AND ALSO GRANT AND DEDICATE A PERPETUAL EASEMENT OVER, UPON AND UNDER THE LANDS DESIGNATED ON THE PLAT AS PUBLIC UTILITY, THE SAME TO BE USED FOR THE INSTALLATION, MAINTENANCE AND OPERATION OF PUBLIC UTILITY SERVICE LINES, STORM DRAINAGE FACILITIES OR FOR THE PERPETUAL PRESERVATION OF WATER DRAINAGE CHANNELS IN THEIR NATURAL STATE WHICHEVER IS APPLICABLE AS MAY BE AUTHORIZED BY WEST HAVEN CITY, UTAH, WITH NO BUILDINGS OR STRUCTURES BEING ERECTED WITHIN SUCH EASEMENTS, AND ALSO DEDICATE, GRANT AND CONVEY TO WEST HAVEN CITY THAT CERTAIN PORTION OF SAID TRACT DESIGNATED HEREON AS PARCEL "A", THE SAME TO BE USED OF THE INSTALLATION, MAINTENANCE AND OPERATION OF PUBLIC UTILITY SERVICE LINES, STORM DRAINAGE FACILITIES OR FOR THE PERPETUAL PRESERVATION OF WATER DRAINAGE CHANNELS IN THEIR NATURAL STATE, WHICHEVER IS APPLICABLE AS MAY BE AUTHORIZED BY WEST HAVEN CITY, UTAH.

SIGNED THIS 12 DAY OF September 2019.

By: Josh Lynch, Owner
Woodmere Homes

ACKNOWLEDGEMENT

STATE OF UTAH)
COUNTY OF WEBER)

On this 12 day of September 2019, personally appeared before me Josh Lynch (NAME OF DOCUMENT SIGNER), whose identity is personally known to me (or proven on the basis of satisfactory evidence) and who, by me duly sworn/affirmed, did say that he/she is the (TITLE OR OFFICE) of (NAME OF CORPORATION), and that said document was signed by him/her in behalf of said "Corporation by Authority of its Bylaws, or (Resolution of its Board of Directors), and said (NAME OF DOCUMENT SIGNER) acknowledged to me that said "Corporation executed the same.

STAMP

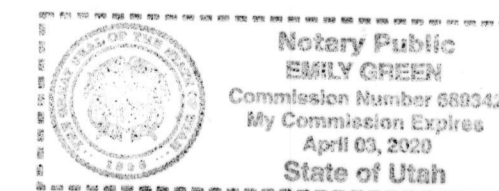

By: Sheryl Green
NOTARY PUBLIC

RECEIVED
SEP 17 2019
BY: 6341

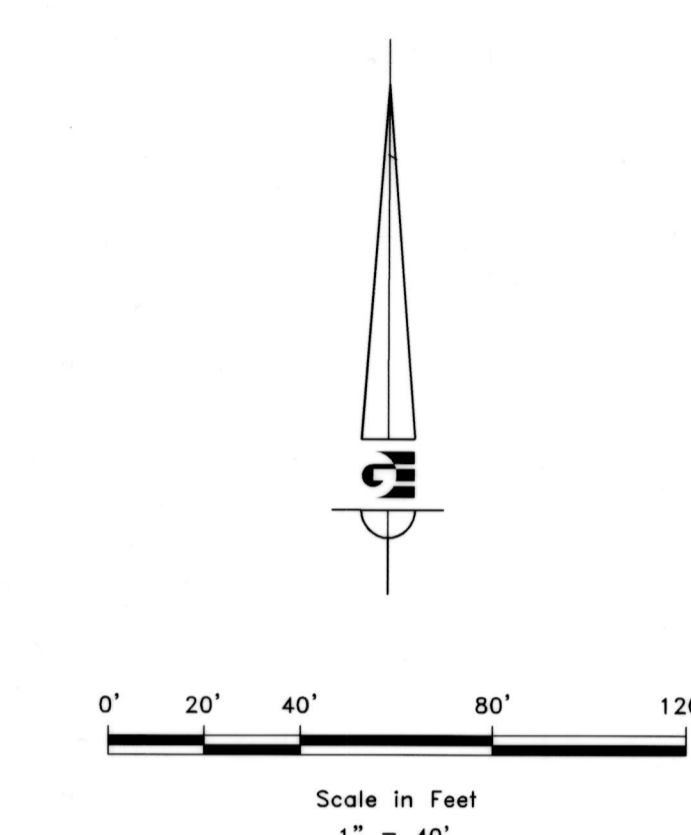
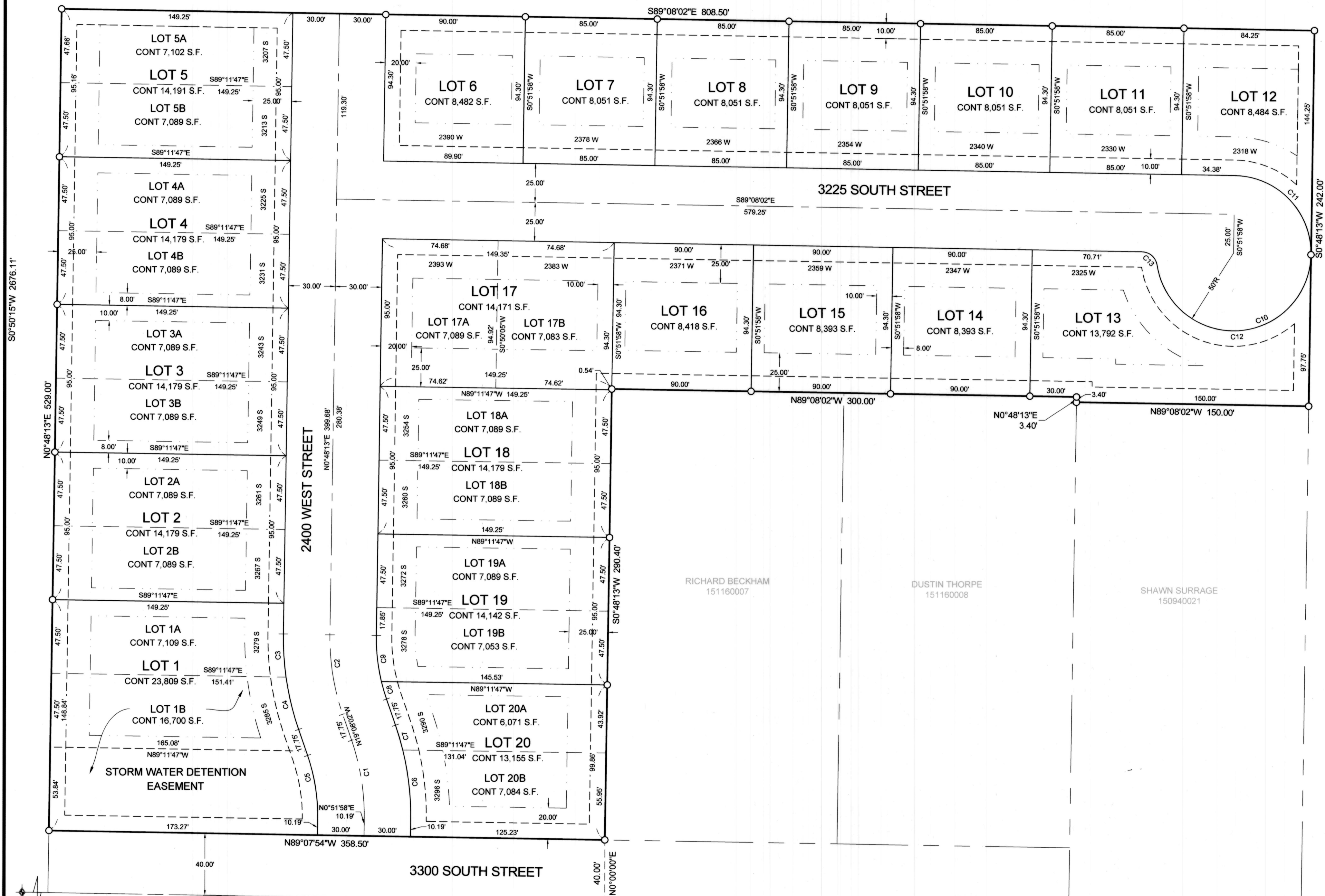

- LEGEND
- ◆ WEBER COUNTY MONUMENT AS NOTED
 - SET 2" REBAR AND CAP MARKED GARDNER ENGINEERING
 - SUBDIVISION BOUNDARY
 - LOT LINE
 - - - ADJACENT PARCEL
 - - - SECTION LINE
 - - - 10' PUBLIC UTILITY EASEMENT (PUE)
 - - - SETBACK LINE
 - X — EXISTING FENCE LINE

FOUND SOUTHWEST CORNER SEC. 35, T6N, R2W, SLB&M 3" W.C. BRASS CAP-2004

FOUND SOUTH QUARTER CORNER SEC. 35, T6N, R2W, SLB&M 3" W.C. BRASS CAP-1971

<p>WEST HAVEN ATTORNEY</p> <p>I HAVE EXAMINED THE FOREGOING PLAT AND DESCRIPTION OF YULISA ESTATES AND IN MY OPINION, THEY CONFORM WITH THE CITY ORDINANCES APPLICABLE THERETO AND NOW IN FORCE AND EFFECT.</p> <p>SIGNED THIS <u>7</u> DAY OF <u>Aug</u> 2019.</p> <p><u>[Signature]</u> CITY ATTORNEY</p>	<p>WEST HAVEN ENGINEER</p> <p>I HEREBY CERTIFY THAT THE REQUIREMENTS OF ALL APPLICABLE STATUTES AND ORDINANCES PREREQUISITE TO CITY ENGINEER APPROVAL OF THE FOREGOING PLAT AND DEDICATIONS HAVE BEEN COMPLIED WITH.</p> <p>SIGNED THIS <u>7</u> DAY OF <u>Aug</u> 2019.</p> <p><u>[Signature]</u> CITY ENGINEER</p>	<p>WEST HAVEN APPROVAL AND ACCEPTANCE</p> <p>THIS IS TO CERTIFY THAT THIS PLAT AND THE DEDICATION OF THIS PLAT, ALONG WITH THE DEDICATION OF ALL STREETS, EASEMENTS AND OTHER PUBLIC IMPROVEMENTS GUARANTEE WERE DULY APPROVED AND ACCEPTED BY THE CITY COUNCIL AND MAYOR OF WEST HAVEN, UTAH.</p> <p>SIGNED THIS <u>14th</u> DAY OF <u>August</u> 2019.</p> <p><u>[Signature]</u> MAYOR, WEST HAVEN</p> <p>ATTEST: <u>[Signature]</u> CITY RECORDER</p>	<p>WEST HAVEN PLANNING COMMISSION</p> <p>THIS IS TO CERTIFY THAT THIS SUBDIVISION WAS DULY APPROVED BY THE WEST HAVEN PLANNING COMMISSION.</p> <p>SIGNED THIS <u>14th</u> DAY OF <u>August</u> 2019.</p> <p><u>[Signature]</u> CHAIRMAN, WEST HAVEN PLANNING COMMISSION</p>	<p>NARRATIVE</p> <p>THE PURPOSE OF THIS SURVEY WAS TO CREATE A TWO LOT SUBDIVISION ON THE PROPERTY AS SHOWN AND DESCRIBED HEREON. THE SURVEY WAS ORDERED BY WOODMERE HOMES. THE CONTROL USED TO ESTABLISH THE BOUNDARY WAS THE EXISTING WEBER COUNTY SURVEY MONUMENTATION AS SHOWN AND NOTED HEREON. THE BASIS OF BEARING IS THE SOUTH LINE OF THE SOUTHWEST QUARTER OF SECTION 35, TOWNSHIP 6 NORTH, RANGE 2 WEST, OF THE SALT LAKE BASE AND MERIDIAN WHICH BEARS NORTH 89°07'54" WEST WEBER COUNTY, UTAH NORTH, NAD 83 STATE PLANE GRID BEARING. THE RIGHT-OF-WAY OF 3300 SOUTH STREET WAS ESTABLISHED BY THE KAP SUBDIVISION.</p>	<p>NOTES</p> <ol style="list-style-type: none"> CURRENT R-4 ZONE SUBJECT PROPERTY FALLS WITHIN FEMA FLOOD ZONE "X" - AREAS DETERMINED TO BE OUTSIDE THE 0.2% ANNUAL CHANCE FLOODPLAIN. PER FEMA MAP NO. 49057C0425E WITH AN EFFECTIVE DATE OF DECEMBER 16, 2005. COPPER RIVET TO BE SET IN CURB AT SIDE LOT LINE EXTENSION.
------------------------------------------------------------------------------------------------------------------------------------------------------------------------------------------------------------------------------------------------------------------------------------------------------------------------	---------------------------------------------------------------------------------------------------------------------------------------------------------------------------------------------------------------------------------------------------------------------------------------------------------------------------------	------------------------------------------------------------------------------------------------------------------------------------------------------------------------------------------------------------------------------------------------------------------------------------------------------------------------------------------------------------------------------------------------------------------------------------------------------------------------------------	---------------------------------------------------------------------------------------------------------------------------------------------------------------------------------------------------------------------------------------------------------------------------------------------------	---------------------------------------------------------------------------------------------------------------------------------------------------------------------------------------------------------------------------------------------------------------------------------------------------------------------------------------------------------------------------------------------------------------------------------------------------------------------------------------------------------------------------------------------------------------------------------------------------------------------------------------------	---------------------------------------------------------------------------------------------------------------------------------------------------------------------------------------------------------------------------------------------------------------------------------------------------------------------------------------------------------------------

<p>DEVELOPER: WOODMERE HOMES JOSH LYNCH 1845 W 4400 S, ROY UTAH 801-416-3252</p>	<p>S1 1</p>	<p>COUNTY RECORDER</p> <p>ENTRY NO. _____ FEE PAID _____</p> <p>FILED FOR AND RECORDED _____</p> <p>AT _____ IN BOOK _____ OF OFFICIAL _____</p> <p>RECORDS, PAGE _____ RECORDED _____</p> <p>FOR _____</p> <p>COUNTY RECORDER _____</p> <p>BY: _____</p>
<p>GARDNER ENGINEERING</p> <p>CIVIL - LAND PLANNING MUNICIPAL - LAND SURVEYING</p> <p>5150 SOUTH 375 EAST OGDEN, UT OFFICE: 801-476-0202 FAX: 801-476-0066</p>		

R-2329 - WOODMERE HOMES1901 - YULISA ESTATES SURVEY FOR WOODMERE HOMES