

- LEGEND**
- Subject Property Line
 - - - Adjoining Property Line
 - - - Ditch
 - - - Top of Bank
 - - - Edge of Gravel
 - - - Fence Line
 - - - Existing 5.0 Contour
 - - - Existing 1.0 Contour
 - Well
 - Found Survey Marker set by others
 - Set 5/8"x24" Rebar With Cap
 - Section Corner

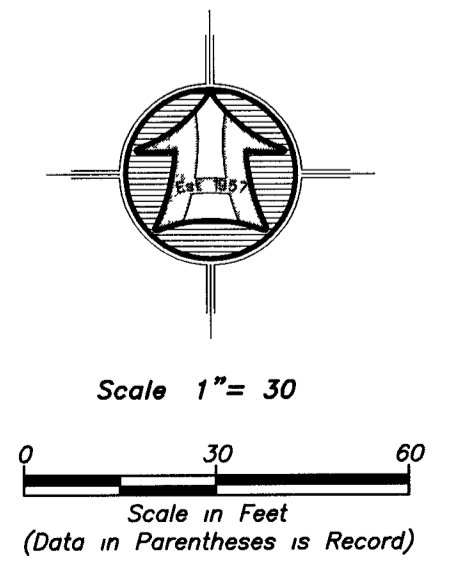

BOUNDARY DESCRIPTION
 ALL OF LOT 570 EVERGREEN PARK SUBDIVISION NO 1 WEBER COUNTY UTAH

Narrative
 The purpose of this survey was to perform a topographic survey and to establish and set the property corners of the parcel as shown and described hereon. The survey was ordered by Carol Merrell. The control used to establish the property corners was ROS# 189 recorded in the Weber County Records Office along with the existing Weber County Survey Monumentation surrounding Section 32 T7N R3E SLB&M. The basis of bearing is the East line of said Section which bears South 0° 04' 14" West an Assumed bearing as shown on said ROS# 189. ROS# 189 is a "Record of Survey for Remonumenting Lot Corners in Evergreen Park Subdivision No 1"

SURVEYOR'S CERTIFICATE
 I, K Greg Hansen, do hereby certify that I am a Registered Professional Land Surveyor in the State of Utah in accordance with Title 58, Chapter 22, Professional Engineers and Professional Land Surveyors Act and by the authority of the owners I have completed a survey of the property described and shown hereon this plat in accordance with Section 17-23-17 and have verified all measurements and that the same has been surveyed and monuments have been located and/or placed on the ground as represented on the plat hereon.
 Signed this 22nd day of August, 2019
 K Greg Hansen PLS
 Utah Land Surveyor Licence No 167819



RECEIVED
 JAN 13 2020
 BY 6403

<p>HANSEN & ASSOCIATES, INC Consulting Engineers and Land Surveyors 538 North Main Street Brigham Utah 84302 Visit us at www.hansen.net Brigham City Ogden Logan (435) 723-3491 (801) 399-4965 (435) 732-8272 Celebrating over 60 Years of Business</p>	
<p>HAI</p>	<p>Drawn By: RS Date: 08/22/2019 Designed By: _____ Checked By: _____ Approved By: _____ Scale: 1" = 30' Drawing File: 19-3-194615_081419.dwg JOB NUMBER: 19-3-194</p>
<p>Topographic & Property Survey for Russell Merrell 13326 East Oak Canyon Road Huntsville Weber County Utah A Part of the Southeast Quarter of Section 29 Township 7 North Range 3 East S.L.B.&M</p>	<p>Sheet 1 of 1 Sheets</p>