

NORTH QUARTER CORNER SECTION 5,  
T5N, R2W, S.L.B.&M. FOUND WEBER  
COUNTY BRASS CAP MONUMENT

CENTER QUARTER CORNER SECTION 5,  
T5N, R2W, S.L.B.&M. FOUND WEBER  
COUNTY BRASS CAP MONUMENT

NORTHWEST CORNER OF THE  
SOUTHWEST QUARTER OF  
NORTHEAST QUARTER  
PER PROPORTIONATE MEASUREMENT

4700 WEST STREET  
N0°30'08"E 2881.48'

3525 WEST STREET

SECTION LINE

PHILLIP GARR  
080370070  
CONTAINING 1.00 ACRES  
HELD FENCE LINE AND  
SOUTH LINE OF CHARLES  
GREEN SUBDIVISION PHASE 1

RIGHT-OF-WAY LINE PER  
WOODSTONE SUBDIVISION PHASE 4

P.O.B.

527.48'  
(510 B.R.)

DONALD PETERSON  
080370094

150.00'

149.89'

282.77'

PHILLIP GARR  
080370070  
CONTAINING 1.00 ACRES

N88°53'21"W 290.40'

N1°05'16"E 150.00'

S88°53'21"E 290.40'

S1°05'16"W 150.00'

11.63'

210.11'

150.00'

150.00'

149.89'

282.77'

170.75'

238.00'

421.70'

421.70'

421.70'

421.70'

421.70'

421.70'

421.70'

421.70'

421.70'

421.70'

421.70'

421.70'

421.70'

421.70'

421.70'

421.70'

421.70'

421.70'

421.70'

421.70'

421.70'

421.70'

421.70'

421.70'

421.70'

421.70'

421.70'

421.70'

421.70'

421.70'

421.70'

421.70'

421.70'

421.70'

**BOUNDARY DESCRIPTION**

A PART OF THE NORTH HALF OF SECTION 5, TOWNSHIP 5 NORTH, RANGE 2 WEST, OF THE SALT LAKE BASE AND MERIDIAN. BEGINNING AT A POINT BEING LOCATED NORTH 00°30'08" EAST 527.48 FEET ALONG SAID WEST LINE AND NORTH 88°53'21" WEST 11.63 FEET FROM THE SOUTHWEST CORNER OF SAID NORTHEAST QUARTER; RUNNING THENCE NORTH 01°05'16" EAST 150.00 FEET; THENCE SOUTH 88°53'21" EAST 290.40 FEET; THENCE SOUTH 01°05'16" WEST 150.00 FEET; THENCE NORTH 88°53'21" WEST 290.40 FEET TO THE POINT OF BEGINNING. CONTAINING 1.00 ACRES.

SCALE:	1"=100' XREF
DATE:	11/14/19
DESIGN:	
DRAWN:	KHW
CHECKED:	KHW
DWG. NO.:	R20201 - MISC SURVEY TEST - PHILLIP GARR SURVEY DWG

**RECEIVED**  
JAN 16 2020  
6114

PROPERTY SURVEY FOR PHILLIP GARR  
3570 SOUTH 4700 WEST, WEST HAVEN UTAH  
LOCATED IN THE NORTHEAST QUARTER OF SECTION 5,  
TOWNSHIP 5 NORTH, RANGE 2 WEST, S.L.B. AND M.

**GARDNER ENGINEERING**  
CIVIL - LAND PLANNING  
MUNICIPAL - LAND SURVEYING  
5150 SOUTH 375 EAST, OGDEN, UT  
OFFICE: 801-476-0202 FAX: 801-476-0056

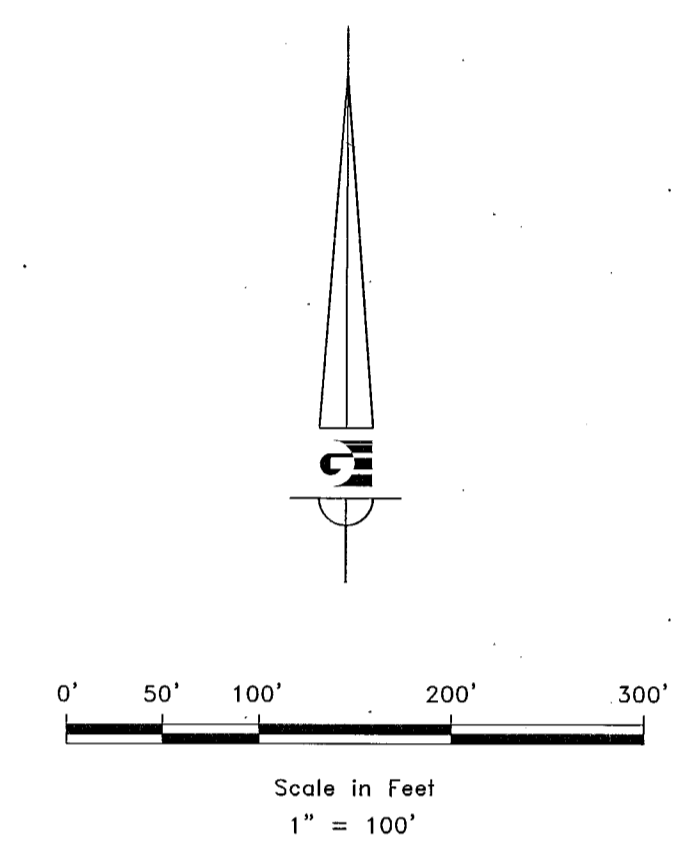

**LEGEND**

- ◆ WEBER COUNTY MONUMENT AS NOTED
- SET 24" REBAR AND CAP MARKED GARDNER ENGINEERING
- SUBDIVISION BOUNDARY
- LOT LINE
- ADJACENT PARCEL
- SECTION LINE
- - - EASEMENT
- X — EXISTING FENCE LINE

**NARRATIVE**

THE PURPOSE OF THIS SURVEY WAS TO ESTABLISH AND SET THE PROPERTY CORNERS OF THE PARCEL AS SHOWN AND DESCRIBED HEREON. THE SURVEY WAS ORDERED BY PHILLIP GARR. THE BASIS OF BEARING IS THE WEST LINE OF THE NORTHEAST QUARTER OF SECTION 5, TOWNSHIP 5 NORTH, RANGE 2 WEST WHICH BEARS NORTH 00°30'08" EAST, WEBER COUNTY, UTAH NORTH, NAD 83 STATE PLANE GRID BEARING.

**SURVEYOR'S CERTIFICATE**

I, KLINT H. WHITNEY, DO HEREBY CERTIFY THAT I AM A LICENSED PROFESSIONAL LAND SURVEYOR IN THE STATE OF UTAH AND THAT I HOLD CERTIFICATE NO. 8227228 IN ACCORDANCE WITH TITLE 58, CHAPTER 22, OF THE PROFESSIONAL ENGINEERS AND LAND SURVEYORS ACT; I FURTHER CERTIFY THAT BY AUTHORITY OF THE OWNERS I HAVE COMPLETED A SURVEY OF THE PROPERTY DESCRIBED ON THIS RECORD OF SURVEY PLAT IN ACCORDANCE WITH SECTION 17-23-20 AND HAVE VERIFIED ALL MEASUREMENTS; THAT THE REFERENCE MONUMENTS SHOWN ON THIS RECORD OF SURVEY PLAT ARE LOCATED AS INDICATED AND ARE SUFFICIENT TO RETRACE OR REESTABLISH THIS SURVEY; AND THAT THE INFORMATION SHOWN HEREIN IS SUFFICIENT TO ACCURATELY ESTABLISH THE LATERAL BOUNDARIES OF THE HEREIN DESCRIBED TRACT OF REAL PROPERTY.

SIGNED THIS 16<sup>TH</sup> DAY OF JANUARY, 2020.

PROFESSIONAL LAND SURVEYOR  
8227228  
Klint H. Whitney  
STATE OF UTAH  
KLINT H. WHITNEY, PLS NO. 8227228

S1  
2