

BOUNDARY DESCRIPTION
 ALL OF LOT 119 RIVER VALLEY ESTATES SUBDIVISION, RIVERDALE CITY, WEBER COUNTY, UTAH,
 ACCORDING TO THE OFFICIAL PLAT THEREOF.

SCALE: 1/20" X REF	DATE: 4/16/15	DESIGN: _____	DRAWN: KHW	CHECKED: KHW
REVISIONS	DESCRIPTION			
DATE				

RECEIVED
 JAN 16 2020
 BY: 6425

PROPERTY SURVEY FOR CAROLINE RODRIGUEZ
 3740 SOUTH RIVER VALLEY DRIVE
 LOCATED IN THE SOUTHWEST QUARTER OF SECTION 6,
 TOWNSHIP 5 NORTH, RANGE 1 WEST, S.L.B. AND M.

GARDNER ENGINEERING
 CIVIL - LAND PLANNING
 MUNICIPAL - LAND SURVEYING
 5150 SOUTH 375 EAST, GORDEN, UT
 OFFICE: 801-476-0202 FAX: 801-476-0066

KLINT H. WHITNEY
 PROFESSIONAL LAND SURVEYOR
 8227228

S1
 1

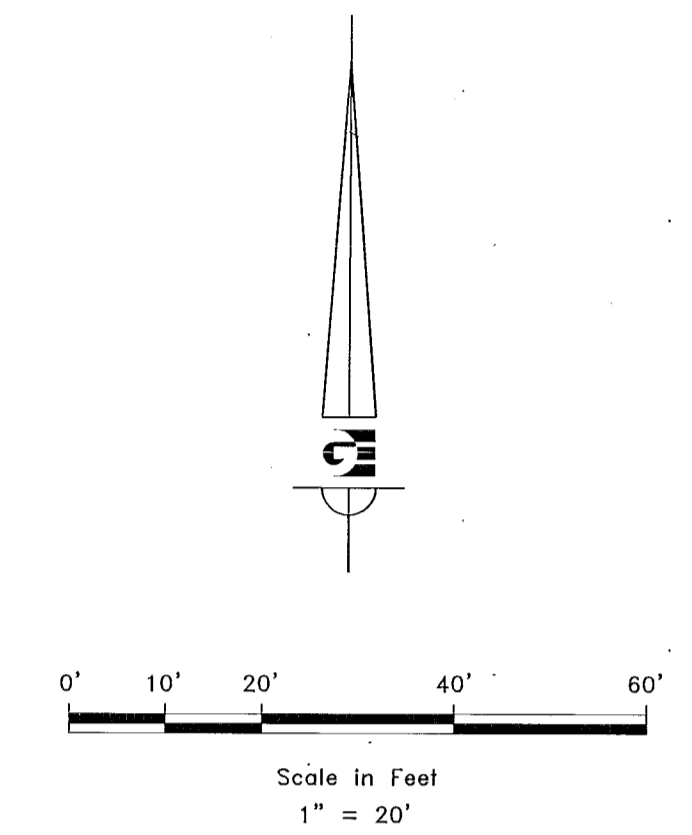

- LEGEND**
- ⊕ WEBER COUNTY MONUMENT AS NOTED
 - SET 24" REBAR AND CAP MARKED GARDNER ENGINEERING
 - SUBDIVISION BOUNDARY
 - LOT LINE
 - - - ADJACENT PARCEL
 - - - SECTION LINE
 - - - EASEMENT
 - x - EXISTING FENCE LINE
 - - - CENTERLINE

NARRATIVE

THE PURPOSE OF THE SURVEY WAS TO ESTABLISH AND SET THE PROPERTY CORNERS OF THE PARCEL AS SHOWN AND DESCRIBED HEREON. THE SURVEY WAS ORDERED BY CAROLINE RODRIGUEZ THE CONTROL USED TO ESTABLISH THE BOUNDARY WAS THE EXISTING WEBER COUNTY MONUMENTATION SURROUNDING SECTION 6, TOWNSHIP 5 NORTH, RANGE 1 WEST, SLB&M AND EXISTING OCCUPATION. THE BASIS OF BEARING IS THE SOUTH LINE OF THE SOUTHWEST QUARTER OF SECTION 6, WHICH BEARS NORTH 88°38'19" WEST WEBER COUNTY, UTAH, NORTH NAD 83 STATE PLANE GRID BEARING. THE DEDICATED PLAT OF RIVER VALLEY ESTATES SUBDIVISION NUMBER 6 RECORDED IN BOOK 15, PAGE 63, AND THE WARRANTY DEED RECORDED AS ENTRY #2669971 WERE USED TO DETERMINE OWNERSHIP.

SURVEYOR'S CERTIFICATE

I, KLINT H. WHITNEY, DO HEREBY CERTIFY THAT I AM A LICENSED PROFESSIONAL LAND SURVEYOR IN THE STATE OF UTAH AND THAT I HOLD CERTIFICATE NO. 8227228 IN ACCORDANCE WITH TITLE 58, CHAPTER 22, OF THE PROFESSIONAL ENGINEERS AND LAND SURVEYORS ACT. I FURTHER CERTIFY THAT BY AUTHORITY OF THE OWNERS I HAVE COMPLETED A SURVEY OF THE PROPERTY DESCRIBED ON THIS RECORD OF SURVEY PLAT IN ACCORDANCE WITH SECTION 17-23-20 AND HAVE VERIFIED ALL MEASUREMENTS; THAT THE REFERENCE MONUMENTS SHOWN ON THIS RECORD OF SURVEY PLAT ARE LOCATED AS INDICATED AND ARE SUFFICIENT TO RETRACE OR REESTABLISH THIS SURVEY; AND THAT THE INFORMATION SHOWN HEREIN IS SUFFICIENT TO ACCURATELY ESTABLISH THE LATERAL BOUNDARIES OF THE HEREIN DESCRIBED TRACT OF REAL PROPERTY.

SIGNED THIS 16TH DAY OF JANUARY, 2020.

PROFESSIONAL LAND SURVEYOR
 1/16/20
 8227228
 Klint H. Whitney
 STATE OF UTAH
 KLINT H. WHITNEY, PLS NO. 8227228



SOUTHWEST CORNER SEC. 6, T5N, R1W, SLB&M. FOUND 3" WEBER COUNTY BRASS CAP MONUMENT IN CONCRETE FLUSH WITH GROUND, FAIR CONDITION, 1967.

194.59'
 N88°38'19"W 2632.87'