

**LOT 8**  
**LOT 9**  
**LOT 10**

**BLOCK 5, PLAT "A"**

**TRAVIS ON GRANT LLC**  
01-005-0036  
CONT. 0.177 ACRES

**NARRATIVE**  
THE PURPOSE OF THIS SURVEY WAS TO ESTABLISH AND SET THE PROPERTY CORNERS OF THE PARCEL AS SHOWN AND DESCRIBED HEREON. THE SURVEY WAS ORDERED BY TABRA CHRISENBERY. THE CONTROL USED TO ESTABLISH THE PROPERTY CORNERS WAS THE EXISTING OGDEN CITY SURVEY MONUMENTATION SURROUNDING BLOCK 5, PLAT A. THE BASIS OF BEARING IS THE CENTERLINE OF GRANT AVENUE FROM 27TH STREET TO 28TH STREET WHICH BEARS SOUTH 1°18'20" WEST, UTAH NORTH, STATE PLANE, CALCULATED N.A.D.83 BEARING.

**PARCEL NO. 2 AS SURVEYED BOUNDARY DESCRIPTION**

A PART OF LOT 9, BLOCK 5, PLAT A, OGDEN, WEBER COUNTY, UTAH SURVEY. MORE PARTICULARLY DESCRIBED AS FOLLOWS:  
BEGINNING AT THE NORTHEAST CORNER OF SAID LOT 9 BEING A POINT ON THE WEST RIGHT-OF-WAY LINE OF GRANT AVENUE LOCATED 315.77 FEET SOUTH 01°18'20" WEST ALONG THE CENTERLINE OF GRANT AVENUE AND 49.50 FEET NORTH 88°40'59" WEST FROM THE OGDEN CITY SURVEY MONUMENT AT THE INTERSECTION OF GRANT AVENUE AND 27TH STREET;  
RUNNING THENCE SOUTH 01°18'20" WEST (SOUTH BY RECORD) 55.00 FEET ALONG SAID WEST RIGHT-OF-WAY LINE; THENCE NORTH 88°40'59" WEST (WEST BY RECORD) 140.00 FEET; THENCE NORTH 01°18'20" EAST (NORTH BY RECORD) 55.00 FEET TO THE NORTH LINE OF SAID LOT 9; THENCE SOUTH 88°40'59" EAST (EAST BY RECORD) 140.00 FEET ALONG SAID NORTH LINE TO THE POINT OF BEGINNING. CONTAINING 0.177 ACRES.

**SURVEYOR'S CERTIFICATE**

I, ROGER C. SLADE, DO HEREBY CERTIFY THAT I AM A REGISTERED PROFESSIONAL LAND SURVEYOR IN THE STATE OF UTAH IN ACCORDANCE WITH TITLE 58, CHAPTER 22, PROFESSIONAL ENGINEERS AND PROFESSIONAL LAND SURVEYORS ACT; AND BY THE AUTHORITY OF THE OWNERS, I HAVE COMPLETED A SURVEY OF THE PROPERTY DESCRIBED AND SHOWN HEREON THIS PLAT IN ACCORDANCE WITH SECTION 17-23-17 AND HAVE VERIFIED ALL MEASUREMENTS, AND THAT THE SAME HAS BEEN SURVEYED AND MONUMENTS HAVE BEEN LOCATED AND/OR PLACED ON THE GROUND AS REPRESENTED ON THE PLAT HEREON.  
SIGNED THIS 27TH DAY OF MAY, 2020.

ROGER C. SLADE, PLS  
UTAH LAND SURVEYOR LICENCE NO. 11386802

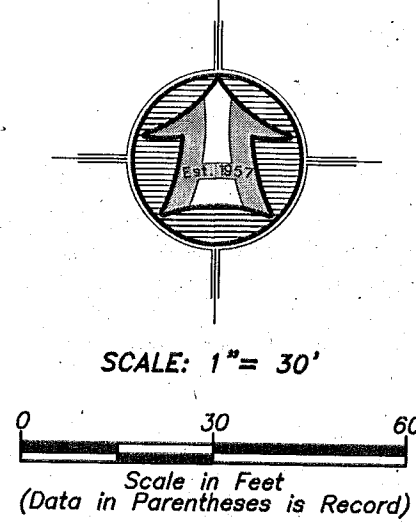

- LEGEND**
- SUBJECT PROPERTY LINE
  - - - SUBDIVISION BOUNDARY
  - ADJOINING PROPERTY LINE
  - CENTERLINE
  - - - ORIGINAL LOT LINE
  - x - x - FENCE LINE
  - ○ ○ STREET MONUMENT
  - ○ ○ FOUND MAG & FLASH SET BY CLS
  - ○ ○ SET 5/8"X24" REBAR WITH CAP

**RECEIVED**  
JUN 3 2020  
BY: 6540

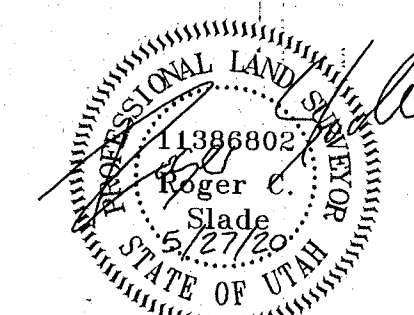

<p><b>PROPERTY SURVEY FOR</b> <b>TRAVIS ON GRANT LLC</b> 2743 GRANT AVE. OGDEN, WEBER CO., UTAH A PART OF LOT 9, BLOCK 5, PLAT "A", OGDEN CITY SURVEY</p>	<p>Drawn By: RS Date: 05/21/20 Designed By: Tgh Checked By: Tgh Approved By: Tgh Scale: 1" = 30' Drawing File: 20-3-83v15.dwg JOB NUMBER: 20-3-93</p>
<p>Sheet <b>1</b> of <b>1</b> Sheets</p>	<p><b>HANSEN &amp; ASSOCIATES, INC.</b> Consulting Engineers and Land Surveyors 538 North Main Street, Brigham, Utah 84302 Visit us at www.haisens.net Brigham City, Ogden, Logan (435) 723-3491 (801) 389-4805 (435) 752-8272 Celebrating over 60 Years of Business</p>