

RIVERSIDE ESTATES SUBDIVISION
(ENTRY NO. 1461434)

LOT 9
TIFFINI CHRISTENSEN
15-217-0004
CONT. 9.00 ACRES

PARCEL NO. 1
TIFFINI CHRISTENSEN
15-011-0051
CONT. 0.222 ACRES

LOT 11
CARY & JAYNE RALSTON FAMILY TRUST
15-590-0002

LOT 10
DANIEL BOUDRERO ETAL
15-590-0001

RIVERSIDE ESTATES SUBDIVISION 1ST AMENDMENT
(ENTRY NO. 2757944)

NARRATIVE

THE PURPOSE OF THIS SURVEY WAS TO ESTABLISH AND SET THE PROPERTY CORNERS OF THE PARCELS AS SHOWN AND DESCRIBED HEREON. THE SURVEY WAS ORDERED BY TIFFINI CHRISTENSEN. THE CONTROL USED TO ESTABLISH THE PROPERTY CORNERS WAS THE OFFICIAL PLAT OF RIVERSIDE ESTATES SUBDIVISION, ENTRY NO. 1461434 ALONG WITH THE EXISTING WEBER COUNTY SURVEY MONUMENTATION SURROUNDING SECTION 4, T6N, R2W, SLB&M.

THE BASIS OF BEARING IS THE SOUTH LINE OF THE SOUTHEAST QUARTER OF SAID SECTION WHICH BEARS NORTH 89°44'50" WEST, UTAH NORTH, STATE PLANE, CALCULATED N.A.D.83 BEARING.

LOT 9
RECORD BOUNDARY DESCRIPTION
PROPERTY TAX ID NO. 15-217-0004

ALL OF LOT 9, RIVERSIDE ESTATES SUBDIVISION, WEBER COUNTY, UTAH SURVEY.

PARCEL NO. 1
AS SURVEYED BOUNDARY DESCRIPTION
PROPERTY TAX ID NO. 15-011-0051

A PART OF THE SOUTHEAST QUARTER OF SECTION 4, TOWNSHIP 6 NORTH, RANGE 2 WEST OF THE SALT LAKE BASE AND MERIDIAN.

BEGINNING AT AN ANGLE POINT IN THE NORTHERLY BOUNDARY OF LOT 9, RIVERSIDE ESTATES SUBDIVISION RECORDED AS ENTRY NO. 1461434 IN THE WEBER COUNTY RECORDER'S OFFICE LOCATED 1126.57 FEET NORTH 88°44'50" WEST ALONG THE SOUTH LINE OF SAID SOUTHEAST QUARTER AND 282.98 FEET NORTH 00°00'00" EAST (NORTH 1°10'26" WEST 282.92 FEET AND NORTH 89°51'36" WEST 1126.43 FEET BY RECORD) FROM THE SOUTHEAST CORNER OF SAID SECTION 4;

RUNNING THENCE SOUTH 63°53'14" EAST (SOUTHEASTERLY BY RECORD) 240.41 FEET TO THE NORTHEAST CORNER OF SAID LOT 9 ALSO BEING A POINT ON THE WEST RIGHT-OF-WAY LINE OF 3650 WEST STREET; THENCE NORTH 00°28'23" WEST (NORTHERLY ALONG COUNTY ROAD 3650 WEST BY RECORD) 90.00 FEET ALONG SAID WEST RIGHT-OF-WAY LINE; THENCE NORTH 85°47'38" WEST 215.72 FEET (WESTERLY 216.0 FEET MORE OR LESS BY RECORD) TO THE POINT OF BEGINNING. CONTAINING 0.222 ACRES.

SURVEYOR'S CERTIFICATE

I, ROGER C. SLADE, DO HEREBY CERTIFY THAT I AM A REGISTERED PROFESSIONAL LAND SURVEYOR IN THE STATE OF UTAH IN ACCORDANCE WITH TITLE 58, CHAPTER 22, PROFESSIONAL ENGINEERS AND PROFESSIONAL LAND SURVEYORS ACT; AND BY THE AUTHORITY OF THE OWNERS, I HAVE COMPLETED A SURVEY OF THE PROPERTY DESCRIBED AND SHOWN HEREON THIS PLAT IN ACCORDANCE WITH SECTION 17-23-17 AND HAVE VERIFIED ALL MEASUREMENTS, AND THAT THE SAME HAS BEEN SURVEYED AND MONUMENTS HAVE BEEN LOCATED AND/OR PLACED ON THE GROUND AS REPRESENTED ON THE PLAT HEREON.

SIGNED THIS 4TH DAY OF AUGUST, 2020.

ROGER C. SLADE, PLS
UTAH LAND SURVEYOR LICENCE NO. 11386802

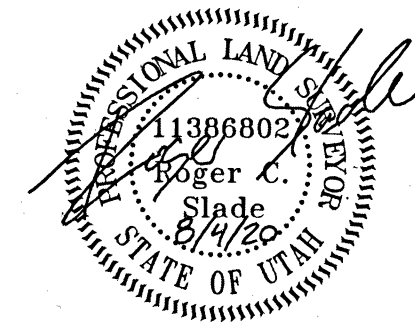

RECEIVED
AUG 24 2020
BY: 0594

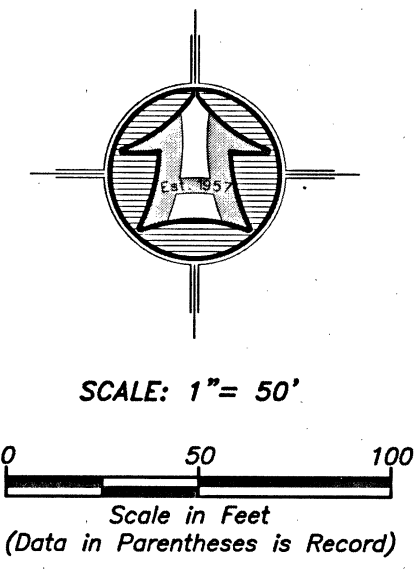

- LEGEND**
- SUBJECT PROPERTY LINE
 - - - - - SUBDIVISION BOUNDARY
 - ADJOINING PROPERTY LINE
 - CENTERLINE
 - - - - - FENCE LINE
 - FOUND REBAR SET BY OTHERS
 - SET 5/8"X24" REBAR WITH CAP
 - SECTION CORNER

<p>Drawn By: RS Date: 08/04/2020</p> <p>Designed By: TCH</p> <p>Checked By: TCH</p> <p>Approved By: TCH</p> <p>Scale: 1" = 50'</p> <p>Drawing File: 20-3-145218.dwg</p> <p>JOB NUMBER: 20-3-145</p>	<p>No. _____</p> <p>Date _____</p> <p>By _____</p> <p>Revision _____</p>
<p>HANSEN & ASSOCIATES, INC. Consulting Engineers and Land Surveyors 538 North Main Street, Brigham, Utah 84302 Visit Us at www.hanseninc.com Brigham City, Utah (435) 723-3491 (801) 399-4905 (435) 753-4872 Celebrating over 60 Years of Business</p>	
<p>PROPERTY SURVEY FOR TIFFINI CHRISTENSEN 1109 NORTH 3650 WEST MARRIOTT-SLATERVILLE, WEBER COUNTY, UTAH A PART OF THE SOUTHEAST QUARTER OF SECTION 4 TOWNSHIP 6 NORTH, RANGE 2 WEST, S.L.B.&M.</p>	
<p>Sheet 1 of 1 Sheets</p>	