

OGDEN CITY SURVEY MONUMENT
AT THE INTERSECTION OF 29TH STREET
AND PINGREE AVENUE.

OGDEN CITY SURVEY MONUMENT
AT THE INTERSECTION OF 30TH STREET
AND PINGREE AVENUE.

BOUNDARY DESCRIPTION PARCEL 040450032

ALL OF LOT 13, BLOCK 1, DUNN'S ADDITION, OGDEN CITY, WEBER COUNTY, UTAH, TOGETHER WITH A RIGHT-OF-WAY OVER THE SOUTH 2.5 FEET OF LOT 12, BLOCK 1, DUNN'S ADDITION, OGDEN CITY, WEBER COUNTY, UTAH.

BOUNDARY DESCRIPTION PARCEL 040450033

ALL OF LOT 14, BLOCK 1, DUNN'S ADDITION, OGDEN CITY, WEBER COUNTY, UTAH.

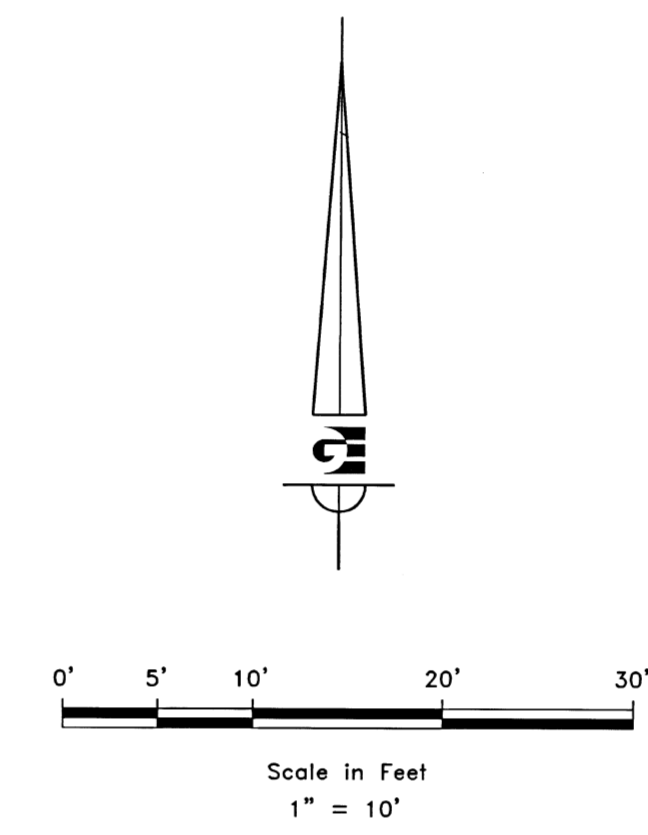

LEGEND

- ◆ OGDEN CITY SURVEY MONUMENT AS NOTED
- SET 24" REBAR AND CAP MARKED GARDNER ENGINEERING
- SUBJECT PROPERTY BOUNDARY
- - - ADJACENT PARCEL
- SECTION LINE
- - - EASEMENT
- EXISTING FENCE
- EXISTING BUILDING
- ORIGINAL LOT LINE

NARRATIVE

THE PURPOSE OF THIS SURVEY WAS TO ESTABLISH AND SET THE PROPERTY CORNERS OF THE PARCEL AS SHOWN AND DESCRIBED HEREON. THE SURVEY WAS ORDERED BY SUNNY DAY HOMES. THE BASIS OF BEARING IS THE STREET CENTERLINE OF PINGREE AVENUE BETWEEN 29TH STREET AND 30TH STREET, WHICH BEARS SOUTH 1°17'50" WEST, WEBER COUNTY, UTAH NORTH, NAD 83 STATE PLANE GRID BEARING. THE BOUNDARY WAS DETERMINED BY WARRANTY DEED(S) RECORDED AS ENTRY NUMBERS 2924327, 2731470, AND THE DEDICATED PLATS OF DUNN'S ADDITION WERE ALSO USED TO DETERMINE BOUNDARY LOCATION ALONG WITH THE FOUND MONUMENTS AS SHOWN AND DESCRIBED HEREON.

SURVEYOR'S CERTIFICATE

I, KLINT H. WHITNEY, DO HEREBY CERTIFY THAT I AM A LICENSED PROFESSIONAL LAND SURVEYOR IN THE STATE OF UTAH AND THAT I HOLD CERTIFICATE NO. 8227228 IN ACCORDANCE WITH TITLE 58, CHAPTER 22, OF THE PROFESSIONAL ENGINEERS AND LAND SURVEYORS ACT; I FURTHER CERTIFY THAT BY AUTHORITY OF THE OWNERS I HAVE COMPLETED A SURVEY OF THE PROPERTY DESCRIBED ON THIS RECORD OF SURVEY PLAT IN ACCORDANCE WITH SECTION 17-23-20 AND HAVE VERIFIED ALL MEASUREMENTS; THAT THE REFERENCE MONUMENTS SHOWN ON THIS RECORD OF SURVEY PLAT ARE LOCATED AS INDICATED AND ARE SUFFICIENT TO RETRACE OR REESTABLISH THIS SURVEY; AND THAT THE INFORMATION SHOWN HEREIN IS SUFFICIENT TO ACCURATELY ESTABLISH THE LATERAL BOUNDARIES OF THE HEREIN DESCRIBED TRACT OF REAL PROPERTY.

SIGNED THIS 13th DAY OF OCTOBER, 2020.

RECEIVED
OCT 13 2020
BY: 6019



SCALE: 1:10 XREF	DATE: 7/1/20	DESIGN: _____	DRAWN: KHW	CHECKED: KHW
REVISIONS	DATE	DESCRIPTION		
DWG.: 18261 - MSC SURV 0307 - SUNNY DAY HOMES SURV PINGREE AVENUE.DWG				

PROPERTY SURVEY FOR SUNNY DAY HOMES
2937 AND 2939 PINGREE AVENUE, OGDEN, UTAH
LOCATED IN THE WEST HALF OF SECTION 32,
TOWNSHIP 6 NORTH, RANGE 1 WEST, S.L.B. AND M.

GARDNER ENGINEERING
CIVIL - LAND PLANNING
MUNICIPAL - LAND SURVEYING
5150 SOUTH 1575 EAST OGDEN, UT
OFFICE 801.426.0202 FAX 801.426.0066

S1
1