

BOUNDARY DESCRIPTION
 ALL OF LOT 38, PINEVIEW SUMMER HOME AREA RE-SURVEY SUBDIVISION WEBER COUNTY, UTAH.

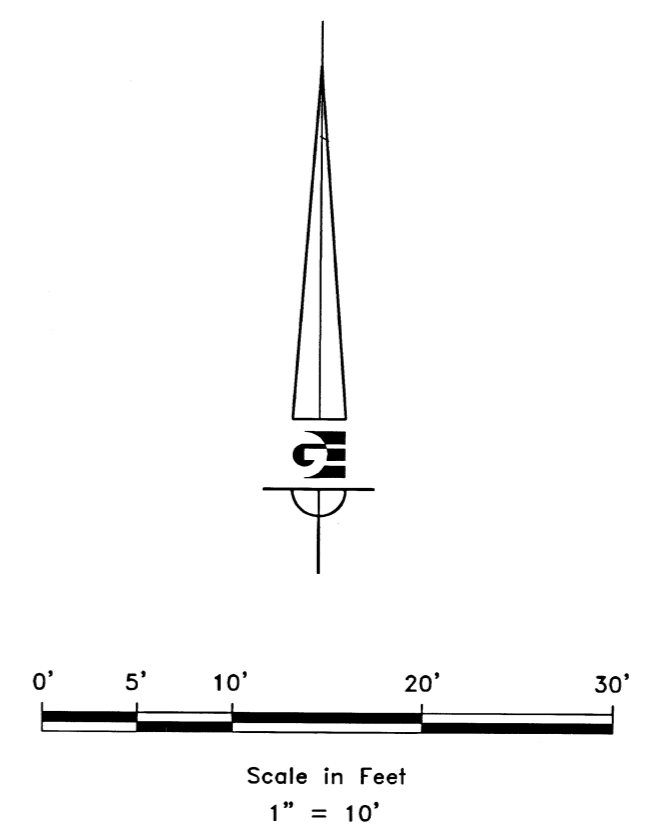

- LEGEND**
- ◆ WEBER COUNTY MONUMENT AS NOTED
 - SET 24\"/>

NARRATIVE

THE PURPOSE OF THIS SURVEY WAS TO ESTABLISH AND SET THE PROPERTY CORNERS OF THE PARCEL AS SHOWN AND DESCRIBED HEREON. THE SURVEY WAS ORDERED BY EMILY SMITH ZURAWSKI. THE BASIS OF BEARING IS THE EAST LINE OF THE SOUTHEAST QUARTER OF SECTION 15, TOWNSHIP 6 NORTH, RANGE 1 EAST WHICH BEARS SOUTH 0°03'30\"/>

SURVEYOR'S CERTIFICATE

I, KLINT H. WHITNEY, DO HEREBY CERTIFY THAT I AM A LICENSED PROFESSIONAL LAND SURVEYOR IN THE STATE OF UTAH AND THAT I HOLD CERTIFICATE NO. 8227228 IN ACCORDANCE WITH TITLE 58, CHAPTER 22, OF THE PROFESSIONAL ENGINEERS AND LAND SURVEYORS ACT. I FURTHER CERTIFY THAT BY AUTHORITY OF THE OWNERS I HAVE COMPLETED A SURVEY OF THE PROPERTY DESCRIBED ON THIS RECORD OF SURVEY PLAT IN ACCORDANCE WITH SECTION 17-23-20 AND HAVE VERIFIED ALL MEASUREMENTS, THAT THE REFERENCE MONUMENTS SHOWN ON THIS RECORD OF SURVEY PLAT ARE LOCATED AS INDICATED AND ARE SUFFICIENT TO RETRACE OR REESTABLISH THIS SURVEY; AND THAT THE INFORMATION SHOWN HEREIN IS SUFFICIENT TO ACCURATELY ESTABLISH THE LATERAL BOUNDARIES OF THE HEREIN DESCRIBED TRACT OF REAL PROPERTY.

SIGNED THIS 13th DAY OF OCTOBER, 2020.

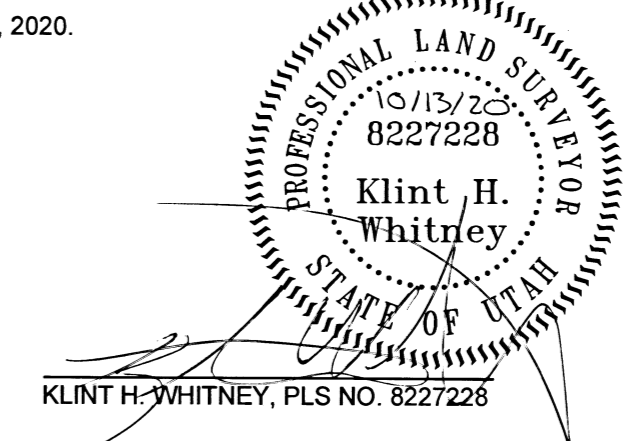

RECEIVED
 OCT 13 2020
 BY: 6652

SCALE: 1" = 10' DATE: 7/17/20 DESIGN: _____ DRAWN: KHW CHECKED: KHW DWG.: B2001 - MISC SURVEY 2000 - EMILY SMITH ZURAWSKI SURVEY/CHERRY SMITH ZURAWSKI DWG	<table border="1" style="width: 100%; border-collapse: collapse;"> <thead> <tr> <th>REVISIONS</th> <th>DESCRIPTION</th> </tr> </thead> <tbody> <tr> <td>DATE</td> <td></td> </tr> </tbody> </table>	REVISIONS	DESCRIPTION	DATE		<p>PROPERTY SURVEY FOR EMILY SMITH ZURAWSKI 5251 E HIGHWAY 39 HUNTSVILLE, UTAH LOCATED IN THE EAST HALF OF SECTION 15, TOWNSHIP 6 NORTH, RANGE 1 EAST, S.L.B. AND M.</p>
REVISIONS	DESCRIPTION					
DATE						
<p>S1</p>		<p>1</p>				