

**PARCEL NO. 1 BOUNDARY DESCRIPTION**  
PROPERTY TAX ID NO. 21-031-0026

A PART OF THE NORTHWEST QUARTER OF SECTION 19, TOWNSHIP 6 NORTH, RANGE 2 EAST, SALT LAKE BASE AND MERIDIAN.  
BEGINNING AT A POINT ON THE SOUTH RIGHT-OF-WAY LINE OF HIGHWAY 39 SAID POINT BEING LOCATED NORTH 89°31'02" EAST 1354.65 FEET AND SOUTH 00°00'00" EAST 1149.70 FEET AND NORTH 65°14'25" WEST 248.37 FEET AND SOUTH 87°18'17" WEST 83.33 FEET FROM THE NORTHWEST CORNER OF SAID SECTION;

RUNNING THENCE SOUTH 24°46'49" WEST 145.57 FEET; THENCE SOUTH 30°27'25" WEST 91.97 FEET; THENCE SOUTH 00°20'01" WEST 55.22 FEET; THENCE NORTH 89°46'56" WEST 110.51 FEET TO AN EXISTING FENCE LINE; THENCE ALONG SAID FENCE LINE THE FOLLOWING FIVE (5) COURSES: (1) SOUTH 18°54'12" EAST 13.54 FEET (2) SOUTH 04°52'26" WEST 106.77 FEET; (3) SOUTH 14°25'42" WEST 90.88 FEET; (4) SOUTH 05°16'57" WEST 137.67 FEET; AND (5) SOUTH 04°40'25" WEST 110.66 FEET TO THE NORTH RIGHT-OF-WAY LINE OF THE HUNTSVILLE SOUTH BENCH CANAL AND AN EXISTING FENCE LINE; THENCE ALONG SAID RIGHT-OF-WAY LINE AND EXISTING FENCE LINE THE FOLLOWING THREE (3) COURSES: (1) SOUTH 74°45'49" WEST 62.82 FEET; (2) SOUTH 68°35'43" WEST 75.78 FEET; AND (3) SOUTH 66°18'10" WEST 88.67 FEET TO AN EXISTING FENCE CORNER; THENCE ALONG AN EXISTING FENCE LINE NORTH 02°38'36" EAST 1027.51 FEET TO SAID SOUTH RIGHT-OF-WAY LINE; THENCE ALONG SAID RIGHT-OF-WAY LINE THE FOLLOWING THREE (3) COURSES: (1) SOUTH 65°14'21" EAST 311.45 FEET; (2) SOUTH 43°24'43" EAST 134.93 FEET; (3) NORTH 87°18'17" EAST 56.97 FEET TO THE POINT OF BEGINNING. CONTAINING 6.031 ACRES.

**PARCEL NO. 2 BOUNDARY DESCRIPTION**  
PROPERTY TAX ID NO. 21-031-0033

A PART OF THE NORTHWEST QUARTER OF SECTION 19, TOWNSHIP 6 NORTH, RANGE 2 EAST, SALT LAKE BASE AND MERIDIAN.  
BEGINNING AT A POINT ON THE SOUTH RIGHT-OF-WAY LINE OF HIGHWAY 39 SAID POINT BEING LOCATED NORTH 89°31'02" EAST 1354.65 FEET AND SOUTH 00°00'00" EAST 1149.70 FEET FROM THE NORTHWEST CORNER OF SAID SECTION;

RUNNING THENCE SOUTH 24°46'49" WEST 629.74 FEET TO THE NORTH RIGHT-OF-WAY LINE OF THE HUNTSVILLE SOUTH BENCH CANAL AND AN EXISTING FENCE LINE; THENCE ALONG SAID NORTH RIGHT-OF-WAY LINE AND EXISTING FENCE LINE THE FOLLOWING THREE (3) COURSES: (1) SOUTH 86°31'18" WEST 45.80 FEET; (2) SOUTH 80°26'51" WEST 106.70 FEET; AND (3) SOUTH 79°59'11" WEST 163.87 FEET TO AN EXISTING FENCE LINE; THENCE ALONG SAID EXISTING FENCE LINE THE FOLLOWING FIVE COURSES: (1) NORTH 04°40'25" EAST 110.66 FEET; (2) NORTH 05°16'57" EAST 137.67 FEET; (3) NORTH 14°25'42" EAST 90.88 FEET; (4) NORTH 04°52'26" EAST 106.77 FEET; AND (5) NORTH 18°54'12" WEST 13.54 FEET; THENCE SOUTH 89°46'56" EAST 110.51 FEET; THENCE NORTH 00°20'01" EAST 55.22 FEET; THENCE SOUTH 65°13'11" EAST 178.47 FEET; THENCE NORTH 24°46'49" EAST 275.57 FEET TO SAID SOUTH RIGHT-OF-WAY LINE; THENCE ALONG SAID RIGHT-OF-WAY LINE SOUTH 65°14'25" EAST 152.93 FEET TO THE POINT OF BEGINNING. CONTAINING 4.506 ACRES.

**NARRATIVE**

THE PURPOSE OF THIS SURVEY WAS TO ADJUST THE BOUNDARY BETWEEN PROPERTY TAX ID NO.'S 21-031-0026 & 21-031-0033 AND TO ESTABLISH AND SET THE PROPERTY CORNERS OF THE PARCELS AS SHOWN AND DESCRIBED HEREON. THE SURVEY WAS ORDERED BY RAY WALKER. THE CONTROL USED TO ESTABLISH THE PROPERTY CORNERS WAS ROS# 4376 ALONG WITH THE EXISTING WEBER COUNTY SURVEY MONUMENTATION SURROUNDING SECTION 19, T6N, R2E, SLB&M.

THE BASIS OF BEARING IS THE NORTH LINE OF SAID SECTION, ASSUMED TO BEAR NORTH 89°31'02" EAST, AS SHOWN ON SAID ROS# 4376.

- LEGEND**
- SUBJECT PROPERTY LINE
  - - - ADJOINING PROPERTY LINE
  - - - PREVIOUS PROPERTY LINE
  - - - CENTERLINE
  - - - EXISTING FENCE
  - - - EXISTING CANAL
  - UDOT RIGHT-OF-WAY MARKER
  - FOUND REBAR SET BY HAI
  - SET 5/8"X24" REBAR WITH CAP
  - SECTION CORNER

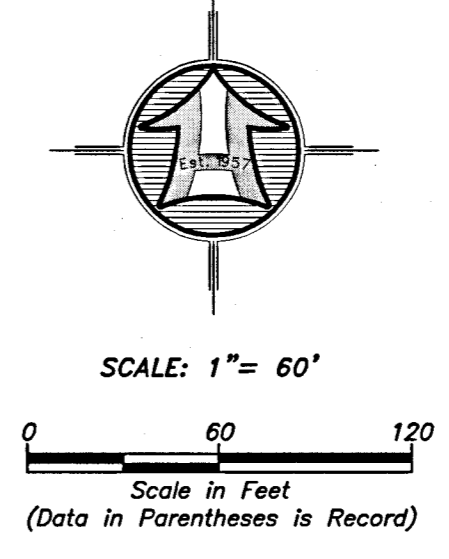

**SURVEYOR'S CERTIFICATE**

I, ROGER C. SLADE, DO HEREBY CERTIFY THAT I AM A REGISTERED PROFESSIONAL LAND SURVEYOR IN THE STATE OF UTAH IN ACCORDANCE WITH TITLE 58, CHAPTER 22, PROFESSIONAL ENGINEERS AND PROFESSIONAL LAND SURVEYORS ACT; AND BY THE AUTHORITY OF THE OWNERS, I HAVE COMPLETED A SURVEY OF THE PROPERTY DESCRIBED AND SHOWN HEREON THIS PLAT IN ACCORDANCE WITH SECTION 17-23-17 AND HAVE VERIFIED ALL MEASUREMENTS, AND THAT THE SAME HAS BEEN SURVEYED AND MONUMENTS HAVE BEEN LOCATED AND/OR PLACED ON THE GROUND AS REPRESENTED ON THE PLAT HEREON.

SIGNED THIS 12TH DAY OF OCTOBER, 2020.

ROGER C. SLADE, PLS  
UTAH LAND SURVEYOR LICENCE NO. 11386802

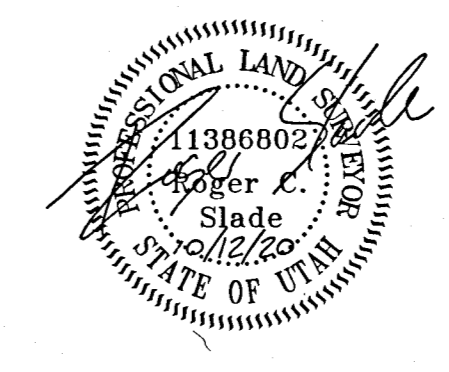

RECEIVED  
OCT 26 2020  
BY: 6671

Drawn By: ES	Date: 10/09/2020
Designed By: Jsh	
Checked By: Jsh	
Approved By: Jsh	
Scale: 1" = 60'	
Drawing File: 20-3-238r18.dwg	
JOB NUMBER: 20-3-238	

**HAI**

**BOUNDARY LINE ADJUSTMENT SURVEY FOR**  
**RAY WALKER**  
7145 EAST HIGHWAY U-39  
HUNTSVILLE, WEBER COUNTY, UTAH  
A PART OF THE NORTHWEST QUARTER OF SECTION 19  
TOWNSHIP 6 NORTH, RANGE 2 EAST, S.L.B.&M.

Sheet	1
of	1
Sheets	

**HANSEN & ASSOCIATES, INC.**  
Consulting Engineers and Land Surveyors  
538 North Main Street, Brigham, Utah 84302  
Visit us at www.hai.com  
Logan Ogden  
(435) 723-3491 (801) 399-4905 (435) 752-8272  
Celebrating over 60 Years of Business

EAST QUARTER CORNER OF SEC. 19, T. 6 N., R. 2 E., SLB&M FOUND WEBER CO. BRASS CAP MONUMENT