

(C1)
 $\Delta = 20'36''.37''$
 $R = 360.00'$
 $L = 129.50'$
 $LC = 128.80'$
 $N 66^\circ16'59'' W$

NARRATIVE
 THE PURPOSE OF THIS SURVEY WAS TO ESTABLISH AND SET THE PROPERTY CORNERS OF THE PARCEL AS SHOWN AND DESCRIBED HEREON. THE SURVEY WAS ORDERED BY JOHN CALLAHAN. THE CONTROL USED TO ESTABLISH THE PROPERTY CORNERS WAS THE OFFICIAL PLAT OF THE CHALETS AT SKI LAKE PHASE 7, RECORDED AS ENTRY NO. 2701785 ALONG WITH THE EXISTING WEBER COUNTY SURVEY MONUMENTATION SURROUNDING SECTION 23, T6N, R1E, SLB&M.
 THE BASIS OF BEARING IS THE NORTH LINE OF THE NORTHEAST QUARTER OF SAID SECTION WHICH BEARS NORTH 89°38'27" WEST, UTAH NORTH, STATE PLANE, CALCULATED N.A.D.83 BEARING AS SHOWN ON THE OFFICIAL PLAT OF THE CHALETS AT SKI LAKE PHASE 7.

RECORD BOUNDARY DESCRIPTION
 ALL OF LOT 48, THE CHALETS AT SKI LAKE PHASE 7, A CLUSTER SUBDIVISION, WEBER COUNTY, UTAH.

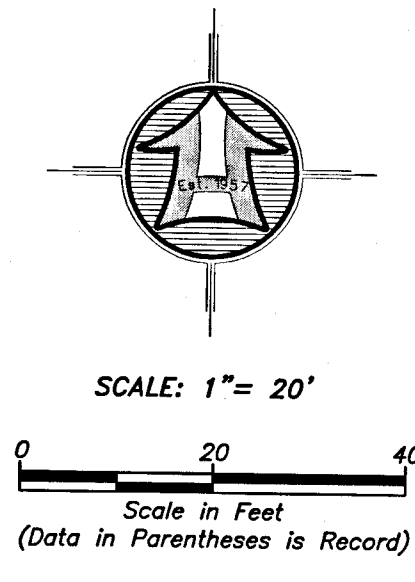

- LEGEND**
- SUBJECT PROPERTY LINE
 - - - ADJOINING PROPERTY LINE
 - CENTERLINE
 - - - SWALE FLOWLINE
 - EXISTING EDGE OF ASPHALT
 - - - EXISTING CONCRETE
 - EXISTING TRAIL
 - STREET MONUMENT
 - FOUND REBAR SET BY OTHERS
 - SET 5/8"x24" REBAR WITH CAP
 - SECTION CORNER

SURVEYOR'S CERTIFICATE
 I, ROGER C. SLADE, DO HEREBY CERTIFY THAT I AM A REGISTERED PROFESSIONAL LAND SURVEYOR IN THE STATE OF UTAH IN ACCORDANCE WITH TITLE 58, CHAPTER 22, PROFESSIONAL ENGINEERS AND PROFESSIONAL LAND SURVEYORS ACT; AND BY THE AUTHORITY OF THE OWNERS, I HAVE COMPLETED A SURVEY OF THE PROPERTY DESCRIBED AND SHOWN HEREON THIS PLAT IN ACCORDANCE WITH SECTION 17-23-17 AND HAVE VERIFIED ALL MEASUREMENTS, AND THAT THE SAME HAS BEEN SURVEYED AND MONUMENTS HAVE BEEN LOCATED AND/OR PLACED ON THE GROUND AS REPRESENTED ON THE PLAT HEREON.

SIGNED THIS _____ DAY OF _____, 2018.

ROGER C. SLADE, PLS
 UTAH LAND SURVEYOR LICENCE NO. 11386802

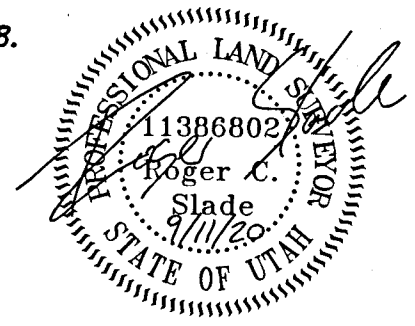

RECEIVED
 OCT 26 2020
 BY: 6671

<p>HANSEN & ASSOCIATES, INC. Consulting Engineers and Land Surveyors 538 North Main Street, Brigham, Utah 84302 Visit us at www.hansen.net Ogden, Utah (435) 752-8272 (435) 233-3491 (cell) 399-4905 (fax) 752-8272 Celebrating 60 Years of Business</p>	<p>HAI</p>
<p>Drawn By: RS Date: 09/11/2020 Designed By: _____ Checked By: _____ Approved By: _____ Scale: 1" = 20' Drawing File: 20-3-222/18.dwg JOB NUMBER: 20-3-222</p>	<p>PROPERTY SURVEY FOR JEFF CALLAHAN 6336 EAST HAWKS LANE HUNTSVILLE, WEBER COUNTY, UTAH A PART OF THE NORTHWEST QUARTER OF SECTION 24 TOWNSHIP 6 NORTH, RANGE 1 EAST, S.L.B.&M.</p>
<p>Sheet 1 of 1 Sheets</p>	