

NORTHWEST CORNER OF SEC. 33
T. 7 N., R. 1 E., SLB&M
FOUND WEBER COUNTY BRASS CAP MONUMENT

N 90°00'00" E

1374.83'

SECTION LINE - BASIS OF BEARING
SECTION LINE PER BIG SKY ESTATES NO. 2 (ENTRY NO. 500942)

N 0°32'16" W

SOUTHWEST CORNER OF SEC. 33
T. 7 N., R. 1 E., SLB&M
FOUND BLM BRASS CAP MONUMENT

LOT 62
HARRY & JAMIE SCHMALZ "TRUSTEES"
22-043-0009

(C1)
Δ = 13°04'43"
R = 658.53'
L = 150.32'
LC = 149.99'
N 19°10'54" W

LOT 63
JEFF SEANEY
22-043-0008
CONT. 1.059 ACRES

LOT 64
MAUGHN BROWNING LAND CO. INC.
22-043-0009

BIG SKY ESTATES NO. 2
(ENTRY NO. 500942)

LOT 52

LOT 53

RECORD BOUNDARY DESCRIPTION
ALL OF LOT 63, BIG SKY ESTATES NO. 2, WEBER COUNTY, UTAH.

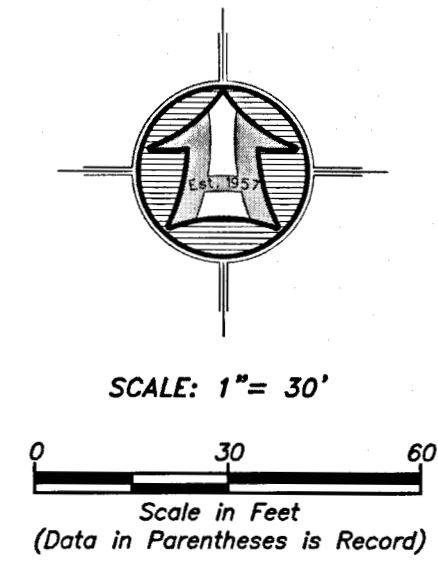

- LEGEND**
- SUBJECT PROPERTY LINE
 - - - SUBDIVISION BOUNDARY
 - - - ADJOINING PROPERTY LINE
 - CENTERLINE
 - - - FENCE LINE
 - FOUND REBAR SET BY HAI
 - SET 5/8"x24" REBAR WITH CAP
 - ◆ SECTION CORNER

NARRATIVE

THE PURPOSE OF THIS SURVEY WAS TO ESTABLISH AND SET THE PROPERTY CORNERS OF LOT 63, BIG SKY ESTATES NO. 2 AS SHOWN AND DESCRIBED HEREON. THE SURVEY WAS ORDERED BY JEFF SEANEY. THE CONTROL USED TO ESTABLISH THE PROPERTY CORNERS WAS THE OFFICIAL PLAT OF SAID BIG SKY ESTATES NO. 2, RECORDED AS ENTRY NO. 500942 AND FOUND REBAR ALONG WITH THE EXISTING WEBER COUNTY SURVEY MONUMENTATION SURROUNDING SECTION 33, T7N, R1E, SLB&M. THE SECTION LINE, AS CURRENTLY MONUMENTED, IS DIFFERENT THAN SHOWN ON THE BIG SKY ESTATES NO. 2 SUBDIVISION PLAT.

THE BASIS OF BEARING IS THE WEST LINE OF SAID SECTION WHICH BEARS NORTH 0°32'16" WEST, AN ASSUMED BEARING, ROTATED TO MATCH THE BEARINGS AS SHOWN ON THE OFFICIAL PLAT OF SAID BIG SKY ESTATES NO. 2.

SURVEYOR'S CERTIFICATE

I, ROGER C. SLADE, DO HEREBY CERTIFY THAT I AM A REGISTERED PROFESSIONAL LAND SURVEYOR IN THE STATE OF UTAH IN ACCORDANCE WITH TITLE 58, CHAPTER 22, PROFESSIONAL ENGINEERS AND PROFESSIONAL LAND SURVEYORS ACT; AND BY THE AUTHORITY OF THE OWNERS, I HAVE COMPLETED A SURVEY OF THE PROPERTY DESCRIBED AND SHOWN HEREON THIS PLAT IN ACCORDANCE WITH SECTION 17-23-17 AND HAVE VERIFIED ALL MEASUREMENTS, AND THAT THE SAME HAS BEEN SURVEYED AND MONUMENTS HAVE BEEN LOCATED AND/OR PLACED ON THE GROUND AS REPRESENTED ON THE PLAT HEREON.

SIGNED THIS 9TH DAY OF NOVEMBER, 2020.

ROGER C. SLADE, PLS
UTAH LAND SURVEYOR LICENCE NO. 11386802



RECEIVED
JAN 04 2021
BY: 6132

<p>PROPERTY SURVEY FOR JEFF SEANEY 2070 NORTH BIG SKY DRIVE WEBER COUNTY, UTAH A PART OF THE SOUTHWEST QUARTER OF SECTION 33 TOWNSHIP 7 NORTH, RANGE 1 EAST, S.L.B.&M.</p>	
<p>Drawn By: RS Designed By: Jsh Checked By: Jsh Approved By: Jsh Scale: 1" = 30' Drawing File: 20-3-271v19.dwg JOB NUMBER: 20-3-271</p>	<p>Date: 10/29/2020</p>
<p>HANSEN & ASSOCIATES, INC. Consulting Engineers and Land Surveyors 538 North Main Street, Brigham, Utah 84302 Visit us at www.hais.net Logan Ogden (435) 723-3491 (801) 399-4905 (435) 752-8272 Celebrating over 60 Years of Business</p>	
<p>Sheet 1 of 1 Sheets</p>	<p>No. Date By Revision</p>