

FOUND OGDEN CITY SURVEY MONUMENT
26TH STREET & MADISON AVE.

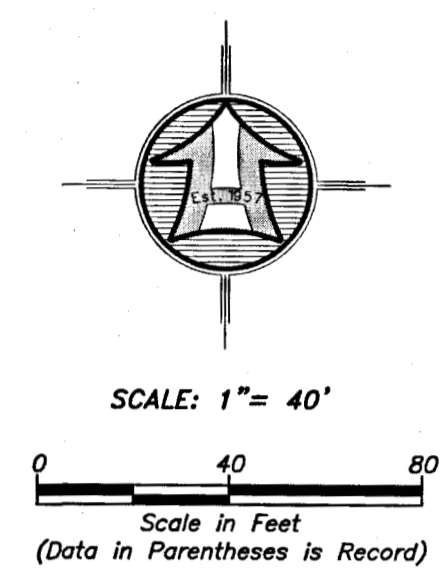

LEGEND

	SUBJECT PROPERTY LINE
	ADJOINING PROPERTY LINE
	PREVIOUS PROPERTY LINE
	ORIGINAL LOT LINE
	CENTERLINE
	FENCE LINE
	FOUND REBAR SET BY HAI
	SET 5/8"x24" REBAR WITH CAP
	OGDEN CITY SURVEY MONUMENT

NARRATIVE

THE PURPOSE OF THIS SURVEY WAS TO AMEND THE BOUNDARY BETWEEN PROPERTY TAX ID NO.'S 01-012-0017 & 0018 AND TO ESTABLISH AND SET THE PROPERTY CORNERS OF THE PARCELS AS SHOWN AND DESCRIBED HEREON. THE SURVEY WAS ORDERED BY CLAY COLEMAN. THE CONTROL USED TO ESTABLISH THE PROPERTY CORNERS WAS THE EXISTING OGDEN CITY SURVEY MONUMENTATION SURROUNDING BLOCK 14, PLAT A.

THE BASIS OF BEARING IS THE CENTERLINE OF JEFFERSON AVENUE WHICH BEARS NORTH 1°18'33" EAST, UTAH NORTH, STATE PLANE, CALCULATED N.A.D.83 BEARING.

PARCEL NO. 1 BOUNDARY DESCRIPTION

A PART OF LOT 5 & LOT 4, BLOCK 14, PLAT A, OGDEN, WEBER COUNTY, UTAH SITUATED IN THE NORTHWEST QUARTER OF SECTION 33, TOWNSHIP 6 NORTH, RANGE 1 WEST OF THE SALT LAKE BASE AND MERIDIAN. MORE PARTICULARLY DESCRIBED AS FOLLOWS:

BEGINNING AT A POINT ON THE EAST RIGHT-OF-WAY LINE OF JEFFERSON AVENUE LOCATED 181.50 FEET NORTH 01°18'33" EAST ALONG THE CENTERLINE OF JEFFERSON AVENUE AND 49.50 FEET SOUTH 88°42'13" EAST AND 35.33 FEET NORTH 01°18'33" EAST FROM THE OGDEN CITY SURVEY MONUMENT AT THE INTERSECTION OF 27TH STREET AND JEFFERSON AVENUE;

RUNNING THENCE NORTH 01°18'33" EAST (NORTH BY RECORD) 49.50 FEET ALONG SAID EAST RIGHT-OF-WAY LINE TO A POINT DESCRIBED OF RECORD AS 7 RODS SOUTH OF THE NORTHWEST CORNER OF SAID LOT 5; THENCE SOUTH 88°42'13" EAST 165.33 FEET (EAST 165.00 FEET BY RECORD); THENCE SOUTH 01°18'23" WEST (SOUTH BY RECORD) 49.50 FEET; THENCE NORTH 88°42'13" WEST (WEST BY RECORD) 165.33 FEET TO THE POINT OF BEGINNING. CONTAINING 0.188 ACRES.

PARCEL NO. 2 BOUNDARY DESCRIPTION

A PART OF LOT 5 & LOT 4, BLOCK 14, PLAT A, OGDEN, WEBER COUNTY, UTAH SITUATED IN THE NORTHWEST QUARTER OF SECTION 33, TOWNSHIP 6 NORTH, RANGE 1 WEST OF THE SALT LAKE BASE AND MERIDIAN. MORE PARTICULARLY DESCRIBED AS FOLLOWS:

BEGINNING AT A POINT DESCRIBED OF RECORD AS 10 RODS SOUTH OF THE NORTHWEST CORNER OF SAID LOT 5, BEING A POINT ON THE EAST RIGHT-OF-WAY LINE OF JEFFERSON AVENUE LOCATED 181.50 FEET NORTH 01°18'33" EAST ALONG THE CENTERLINE OF JEFFERSON AVENUE AND 49.50 FEET SOUTH 88°42'13" EAST FROM THE OGDEN CITY SURVEY MONUMENT AT THE INTERSECTION OF 27TH STREET AND JEFFERSON AVENUE;

RUNNING THENCE NORTH 01°18'33" EAST (NORTH BY RECORD) 35.33 FEET; THENCE SOUTH 88°42'13" EAST (EAST BY RECORD) 165.33 FEET; THENCE SOUTH 01°18'23" WEST (SOUTH BY RECORD) 33.00 FEET; THENCE NORTH 88°42'13" WEST (WEST BY RECORD) 33.00 FEET; THENCE SOUTH 01°18'23" WEST (SOUTH BY RECORD) 2.33 FEET; THENCE NORTH 88°42'13" WEST 132.33 FEET (WEST 8 RODS BY RECORD) TO THE POINT OF BEGINNING. CONTAINING 0.132 ACRES.

SURVEYOR'S CERTIFICATE

I, ROGER C. SLADE, DO HEREBY CERTIFY THAT I AM A REGISTERED PROFESSIONAL LAND SURVEYOR IN THE STATE OF UTAH IN ACCORDANCE WITH TITLE 58, CHAPTER 22, PROFESSIONAL ENGINEERS AND PROFESSIONAL LAND SURVEYORS ACT; AND BY THE AUTHORITY OF THE OWNERS, I HAVE COMPLETED A SURVEY OF THE PROPERTY DESCRIBED AND SHOWN HEREON THIS PLAT IN ACCORDANCE WITH SECTION 17-23-17 AND HAVE VERIFIED ALL MEASUREMENTS, AND THAT THE SAME HAS BEEN SURVEYED AND MONUMENTS HAVE BEEN LOCATED AND/OR PLACED ON THE GROUND AS REPRESENTED ON THE PLAT HEREON.

SIGNED THIS 9TH DAY OF NOVEMBER, 2020.

ROGER C. SLADE, PLS
UTAH LAND SURVEYOR LICENCE NO. 11386802



HANSEN & ASSOCIATES, INC. Consulting Engineers and Land Surveyors 538 North Main Street, Brigham, Utah 84302 Visit us at www.hais.net Logan, Utah (435) 723-4491 (801) 399-4905 (435) 752-8272 Celebrating over 60 Years of Business	
Drawn By: ES Date: 10/29/2020	Checked By: Lsh
Approved By: [Signature]	Scale: 1" = 40'
Drawing File: 20-6-26218.dwg	JOB NUMBER: 20-3-267
BOUNDARY LINE ADJUSTMENT SURVEY FOR CLAY COLEMAN 2660 & 2668 JEFFERSON OGDEN, WEBER COUNTY, UTAH A PART OF THE NORTHWEST QUARTER OF SECTION 33 TOWNSHIP 6 NORTH, RANGE 1 WEST, S.L.B.&M.	
RECEIVED JAN 04 2021 BY: G134	
SURVEYOR'S CERTIFICATE	
SIGNED THIS 9TH DAY OF NOVEMBER, 2020.	
ROGER C. SLADE, PLS UTAH LAND SURVEYOR LICENCE NO. 11386802	
Sheet	1
of	1
Sheets	