

BOUNDARY DESCRIPTION

PART OF THE NORTHWEST QUARTER OF SECTION 19, TOWNSHIP 6 NORTH, RANGE 2 EAST, SALT LAKE BASE AND MERIDIAN, U. S. SURVEY, BEGINNING AT A POINT ON THE NORTH LINE OF STATE HIGHWAY NO. 39 AT ENGINEER'S STATION 43+37.87, SAID POINT BEING 1239.9 FEET WEST AND 1060.12 FEET SOUTH FROM THE NORTHEAST CORNER, NORTHWEST QUARTER OF SAID SECTION 19, RUNNING THENCE NORTH 65°16'28\"/>

SCALE	1" = 40'
DATE	7/1/20
DESIGN	
DRAWN	KHW
CHECKED	KHW

REVISIONS

DATE	DESCRIPTION

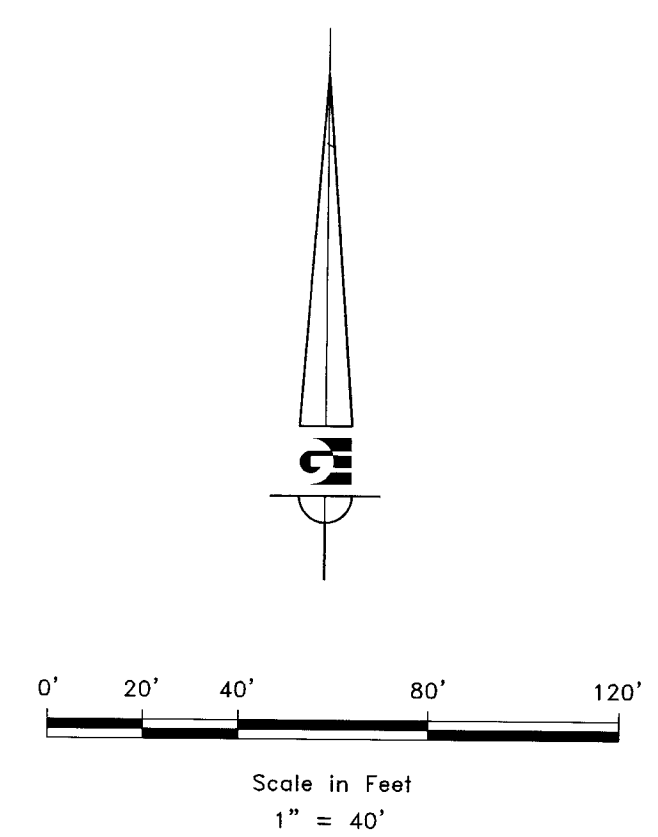

LEGEND

- WEBER COUNTY MONUMENT AS NOTED
- SET 24" REBAR AND CAP MARKED GARDNER ENGINEERING
- SUBJECT PROPERTY BOUNDARY
- LOT LINE
- ADJACENT PARCEL
- SECTION LINE
- EASEMENT
- EXISTING FENCE LINE
- EXISTING BUILDING
- EXISTING ASPHALT
- EXISTING GRAVEL

NARRATIVE

THE PURPOSE OF THIS SURVEY WAS TO ESTABLISH AND SET THE PROPERTY CORNERS OF THE PARCEL AS SHOWN AND DESCRIBED HEREON. THE SURVEY WAS ORDERED BY KRISTINE WILKERSON. THE BASIS OF BEARING IS THE NORTH LINE OF SECTION 19 TOWNSHIP 7 NORTH, RANGE 2 EAST, WHICH BEARS NORTH 89°30'34\"/>

SURVEYOR'S CERTIFICATE

I, KLINT H. WHITNEY, DO HEREBY CERTIFY THAT I AM A LICENSED PROFESSIONAL LAND SURVEYOR IN THE STATE OF UTAH AND THAT I HOLD CERTIFICATE NO. 8227228 IN ACCORDANCE WITH TITLE 58, CHAPTER 22, OF THE PROFESSIONAL ENGINEERS AND LAND SURVEYORS ACT; I FURTHER CERTIFY THAT BY AUTHORITY OF THE OWNERS I HAVE COMPLETED A SURVEY OF THE PROPERTY DESCRIBED ON THIS RECORD OF SURVEY PLAT IN ACCORDANCE WITH SECTION 17-23-20 AND HAVE VERIFIED ALL MEASUREMENTS; THAT THE REFERENCE MONUMENTS SHOWN ON THIS RECORD OF SURVEY PLAT ARE LOCATED AS INDICATED AND ARE SUFFICIENT TO RETRACE OR REESTABLISH THIS SURVEY; AND THAT THE INFORMATION SHOWN HEREIN IS SUFFICIENT TO ACCURATELY ESTABLISH THE LATERAL BOUNDARIES OF THE HEREIN DESCRIBED TRACT OF REAL PROPERTY.

SIGNED THIS 12TH DAY OF FEBRUARY, 2021.

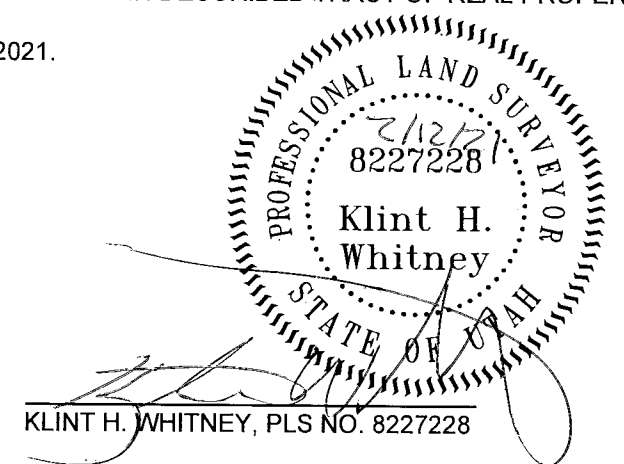

PROPERTY SURVEY FOR KRISTINE WILKERSON
 7238 EAST 900 SOUTH, HUNTSVILLE, UTAH
 LOCATED IN THE NORTHWEST QUARTER OF SECTION 19,
 TOWNSHIP 6 NORTH, RANGE 2 EAST, S.L.B. AND M.

GARDNER ENGINEERING
 CIVIL, LAND PLANNING
 MUNICIPAL - LAND SURVEYING

5150 SOUTH 375 EAST, OGDEN, UT
 OFFICE: 801-476-0202 FAX: 801-476-0066

S1
 1