

PARCEL NO. 1 BOUNDARY DESCRIPTION
 A PART OF THE SOUTHWEST QUARTER OF SECTION 16 AND A PART OF THE NORTHWEST QUARTER OF SECTION 21, TOWNSHIP 6 NORTH, RANGE 2 WEST OF THE SALT LAKE BASE AND MERIDIAN.

BEGINNING AT A POINT ON THE SOUTH RIGHT-OF-WAY LINE OF 900 SOUTH STREET LOCATED 470.44 FEET NORTH 46°40'48" WEST FROM THE SOUTH QUARTER CORNER OF SAID SECTION 16 (BASIS OF BEARING IS THE SOUTH LINE OF SAID SOUTHWEST QUARTER WHICH BEARS NORTH 89°15'33" EAST);
 RUNNING THENCE SOUTH 00°46'14" WEST (SOUTH BY RECORD) 664.08 FEET TO THE NORTH LINE OF BRENT & RENEE WAGSTAFF PROPERTY, TAX ID NO. 15-059-0006; THENCE NORTH 89°15'33" WEST (SOUTH 89°42'11" WEST BY RECORD) 313.06 FEET ALONG SAID NORTH LINE TO THE NORTHEAST CORNER OF PARSLOW'S PLACE SUBDIVISION, RECORDED AS ENTRY NO. 1285426 IN THE WEBER COUNTY RECORDER'S OFFICE; THENCE SOUTH 71°44'27" WEST 230.83 FEET (SOUTH 71°24'42" WEST 229.54 FEET MORE OR LESS BY RECORD) ALONG THE NORTHERLY LINE OF SAID PARSLOW'S PLACE SUBDIVISION TO THE SOUTHEAST CORNER OF CO-OPERATIVE SECURITY CORP. PROPERTY, TAX ID NO. 15-059-0001; THENCE NORTH 01°59'42" EAST (NORTH 01°03'26" EAST BY RECORD) 717.16 FEET ALONG SAID EAST LINE AND THEN ALONG THE WEST LINE OF LOT 29, OF SAID SECTION 16 TO SAID SOUTH RIGHT-OF-WAY LINE; THENCE NORTH 88°16'21" EAST (NORTH 87°34' EAST BY RECORD) 516.44 FEET ALONG SAID SOUTH RIGHT-OF-WAY LINE TO THE POINT OF BEGINNING. CONTAINING 8.022 ACRES.

PARCEL NO. 2 BOUNDARY DESCRIPTION
 A PART OF THE SOUTHWEST QUARTER OF SECTION 16 AND A PART OF THE NORTHWEST QUARTER OF SECTION 21, TOWNSHIP 6 NORTH, RANGE 2 WEST OF THE SALT LAKE BASE AND MERIDIAN.

BEGINNING AT A POINT ON THE SOUTH RIGHT-OF-WAY LINE OF 900 SOUTH STREET LOCATED 470.44 FEET NORTH 46°40'48" WEST FROM THE SOUTH QUARTER CORNER OF SAID SECTION 16 (BASIS OF BEARING IS THE SOUTH LINE OF SAID SOUTHWEST QUARTER WHICH BEARS NORTH 89°15'33" EAST);
 RUNNING THENCE NORTH 88°16'21" EAST (NORTH 87°34' EAST BY RECORD) 173.68 FEET ALONG SAID SOUTH RIGHT-OF-WAY LINE TO THE NORTHWEST CORNER OF LOT 1, HANCOCK HAVEN NO. 1 SUBDIVISION, RECORDED AS ENTRY NO. 1383510 IN THE WEBER COUNTY RECORDER'S OFFICE; THENCE SOUTH 00°46'14" WEST (SOUTH BY RECORD) 671.56 FEET TO THE SOUTHWEST CORNER OF SAID HANCOCK HAVEN NO. 1 SUBDIVISION BEING A POINT ON THE NORTH LINE OF BRENT & RENEE WAGSTAFF PROPERTY, TAX ID NO. 15-059-0006; THENCE NORTH 89°15'33" WEST (SOUTH 89°42'11" WEST BY RECORD) 173.51 FEET ALONG SAID NORTH LINE; THENCE NORTH 00°46'14" EAST 664.08 FEET TO THE POINT OF BEGINNING. CONTAINING 2.660 ACRES.

NARRATIVE
 THE PURPOSE OF THIS SURVEY WAS TO PERFORM A BOUNDARY LINE ADJUSTMENT SURVEY FOR PROPERTY TAX ID NO.'S 15-059-0046 & 15-046-0016 AND TO ESTABLISH AND SET THE PROPERTY CORNERS OF THE PARCELS AS SHOWN AND DESCRIBED HEREON. THE SURVEY WAS ORDERED BY DAVE BOLOS. THE CONTROL USED TO ESTABLISH THE PROPERTY CORNERS WAS THE EXISTING WEBER COUNTY SURVEY MONUMENTATION SURROUNDING SECTIONS 16 & 21, T6N, R2W, SLB&M.
 THE BASIS OF BEARING IS THE SOUTH LINE OF THE SOUTHWEST QUARTER OF SAID SECTION 16 WHICH BEARS NORTH 89°15'33" WEST, UTAH NORTH, STATE PLANE, CALCULATED N.A.D.83 BEARING.

- LEGEND**
- SUBJECT PROPERTY LINE
 - - - ADJOINING PROPERTY LINE
 - - - PREVIOUS PROPERTY LINE
 - - - FENCE LINE
 - - - CENTERLINE
 - FOUND REBAR SET BY OTHERS
 - SET 5/8"x24" REBAR WITH CAP
 - SECTION CORNER

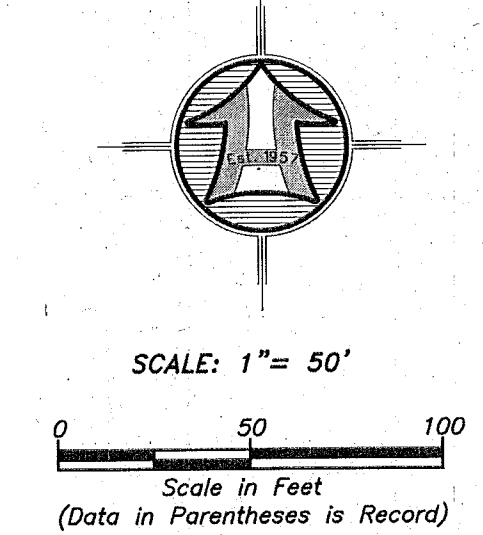

RECEIVED
 APR 27 2021
 BY: 6836

SURVEYOR'S CERTIFICATE
 I, ROGER C. SLADE, DO HEREBY CERTIFY THAT I AM A REGISTERED PROFESSIONAL LAND SURVEYOR IN THE STATE OF UTAH IN ACCORDANCE WITH TITLE 58, CHAPTER 22, PROFESSIONAL ENGINEERS AND PROFESSIONAL LAND SURVEYORS ACT; AND BY THE AUTHORITY OF THE OWNERS, I HAVE COMPLETED A SURVEY OF THE PROPERTY DESCRIBED AND SHOWN HEREON THIS PLAT IN ACCORDANCE WITH SECTION 17-23-17 AND HAVE VERIFIED ALL MEASUREMENTS, AND THAT THE SAME HAS BEEN SURVEYED AND MONUMENTS HAVE BEEN LOCATED AND/OR PLACED ON THE GROUND AS REPRESENTED ON THE PLAT HEREON.
 SIGNED THIS 30TH DAY OF DECEMBER, 2020.

ROGER C. SLADE, PLS
 UTAH LAND SURVEYOR LICENCE NO. 11386802

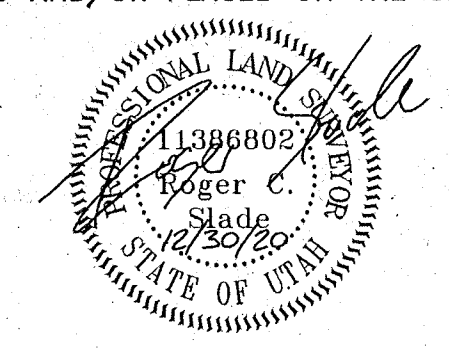

BOUNDARY LINE ADJUSTMENT SURVEY FOR
GENE & LAVON HANCOCK TR
 3989 WEST 900 SOUTH
 WEBER COUNTY, UTAH
 A PART OF THE SW 1/4 OF SECTION 16 & NW 1/4 OF SECTION 21
 TOWNSHIP 6 NORTH, RANGE 2 WEST, S.L.B.&M.

Drawn By: SS
 Designed By: sgh
 Checked By: sgh
 Approved By: [Signature]
 Scale: 1" = 50'
 Drawing File: 20-3-324x19.dwg
 JOB NUMBER: 20-3-324

HANSEN & ASSOCIATES, INC.
 Consulting Engineers and Land Surveyors
 538 North Main Street, Brigham, Utah 84302
 Visit us at www.hansen.net
 Ogden
 Brigham City
 (435) 733-3461 (801) 398-4605 (435) 752-8272
 Celebrating over 60 Years of Business

SHEET
1
 OF
1
 SHEETS