

NORTHWEST CORNER OF SEC. 28,
T. 6 N., R. 2 W., SLB&M
NO MONUMENT FOUND.
CALCULATED POSITION.

NORTH QUARTER CORNER OF SEC. 28,
T. 6 N., R. 2 W., SLB&M
FOUND WEBER CO. BRASS CAP
MONUMENT

SECTION LINE
BASIS OF BEARING
S 89°14'58" E
2643.59'
NORTHEAST CORNER OF SEC. 28,
T. 6 N., R. 2 W., SLB&M
FOUND WEBER CO. BRASS CAP
MONUMENT

P.O.B PARCEL NO.'S 1 & 2, EASEMENT NO.'S 1 & 2
S 89°07'56" E (EAST) 154.01'

P.O.B PARCEL NO. 3
(EAST) S 89°07'56" E 150.99'

PARCEL NO. 1
ROPELATO FAMILY TRUST
15-078-0109
39,435 S.F. OR 0.905 Acres

PARCEL NO. 2
ROPELATO FAMILY TRUST
15-078-0037
24,660 S.F. OR 0.566 Acres

PARCEL NO. 3
ROPELATO FAMILY TRUST
15-078-0044
33,930 S.F. OR 0.779 Acres

MICHAEL & JESSICA ROPELATO
15-078-0077

3900 WEST / TAYLOR PARTNERS, LLC
15-078-0110

PARCEL NO. 1 ADJUSTED BOUNDARY DESCRIPTION
PROPERTY TAX ID NO. 15-078-0109

A PART OF THE NORTHWEST QUARTER OF SECTION 28, TOWNSHIP 6 NORTH, RANGE 2 WEST OF THE SALT LAKE BASE AND MERIDIAN.
BEGINNING AT A POINT ON THE SOUTH RIGHT-OF-WAY LINE OF 1800 SOUTH STREET LOCATED 515.33 FEET NORTH 89°07'56" WEST AND 33.00 FEET SOUTH 00°52'04" WEST FROM THE NORTH QUARTER CORNER OF SAID SECTION 28 (BASIS OF BEARING IS THE NORTH LINE OF THE NORTHEAST QUARTER OF SECTION 28 WHICH BEARS SOUTH 89°14'58" EAST);
RUNNING THENCE SOUTH 02°53'07" WEST 113.61 FEET; THENCE SOUTH 89°07'56" EAST 25.87 FEET; THENCE SOUTH 00°52'04" WEST (SOUTH BY RECORD) 55.89 FEET; THENCE NORTH 89°07'56" WEST (WEST BY RECORD) 125.00 FEET; THENCE NORTH 00°52'04" EAST (NORTH BY RECORD) 315.48 FEET TO SAID SOUTH RIGHT-OF-WAY LINE; THENCE SOUTH 89°07'56" EAST (EAST BY RECORD) 154.01 FEET ALONG SAID SOUTH RIGHT-OF-WAY LINE TO THE POINT OF BEGINNING. CONTAINING 39,435 SQUARE FEET OR 0.905 ACRES.
SUBJECT TO AND TOGETHER AN ACCESS EASEMENT FOR INGRESS AND EGRESS AS SHOWN ON THIS SURVEY.

PARCEL NO. 2 ADJUSTED BOUNDARY DESCRIPTION
PROPERTY TAX ID NO. 15-078-0037

A PART OF THE NORTHWEST QUARTER OF SECTION 28, TOWNSHIP 6 NORTH, RANGE 2 WEST OF THE SALT LAKE BASE AND MERIDIAN.
BEGINNING AT A POINT ON THE SOUTH RIGHT-OF-WAY LINE OF 1800 SOUTH STREET LOCATED 515.33 FEET NORTH 89°07'56" WEST AND 33.00 FEET SOUTH 00°52'04" WEST FROM THE NORTH QUARTER CORNER OF SAID SECTION 28 (BASIS OF BEARING IS THE NORTH LINE OF THE NORTHEAST QUARTER OF SECTION 28 WHICH BEARS SOUTH 89°14'58" EAST);
RUNNING THENCE SOUTH 89°07'56" EAST (EAST BY RECORD) 150.99 FEET ALONG SAID SOUTH RIGHT-OF-WAY LINE; THENCE SOUTH 00°52'04" WEST (SOUTH BY RECORD) 137.00 FEET; THENCE NORTH 89°07'56" WEST (WEST BY RECORD) 180.00 FEET; THENCE SOUTH 00°52'04" WEST (SOUTH BY RECORD) 122.59 FEET; THENCE NORTH 89°07'56" WEST 25.87 FEET; THENCE NORTH 00°52'04" EAST 118.02 FEET; THENCE NORTH 62°00'56" EAST 58.09 FEET; THENCE NORTH 02°53'07" EAST 113.61 FEET TO THE POINT OF BEGINNING. CONTAINING 24,660 SQUARE FEET OR 0.566 ACRES.
SUBJECT TO AND TOGETHER WITH AN ACCESS EASEMENT FOR INGRESS AND EGRESS AS SHOWN ON THIS SURVEY.

PARCEL NO. 3 AS SURVEYED BOUNDARY DESCRIPTION
PROPERTY TAX ID NO. 15-078-0044

A PART OF THE NORTHWEST QUARTER OF SECTION 28, TOWNSHIP 6 NORTH, RANGE 2 WEST OF THE SALT LAKE BASE AND MERIDIAN.
BEGINNING AT A POINT ON THE SOUTH RIGHT-OF-WAY LINE OF 1800 SOUTH STREET LOCATED 364.33 FEET NORTH 89°07'56" WEST AND 33.00 FEET SOUTH 00°52'04" WEST FROM THE NORTH QUARTER CORNER OF SAID SECTION 28 (BASIS OF BEARING IS THE NORTH LINE OF THE NORTHEAST QUARTER OF SECTION 28 WHICH BEARS SOUTH 89°14'58" EAST);
RUNNING THENCE SOUTH 89°07'56" EAST (EAST BY RECORD) 290.00 FEET ALONG SAID SOUTH RIGHT-OF-WAY LINE; THENCE SOUTH 00°52'04" WEST (SOUTH BY RECORD) 117.00 FEET; THENCE NORTH 89°07'56" WEST (WEST BY RECORD) 290.00 FEET; THENCE NORTH 00°52'04" EAST (NORTH BY RECORD) 117.00 FEET TO THE POINT OF BEGINNING. CONTAINING 33,930 SQUARE FEET OR 0.779 ACRES.

NARRATIVE

THE PURPOSE OF THIS SURVEY WAS TO ADJUST THE BOUNDARIES OF PROPERTY TAX ID NO.'S 15-078-0109 & 15-078-0037 AND TO ESTABLISH AND SET THE PROPERTY CORNERS OF THE PARCELS AS SHOWN AND DESCRIBED HEREON. THE SURVEY WAS ORDERED BY CINDY WHITE FOR ROB ROPELATO. THE CONTROL USED TO ESTABLISH THE PROPERTY CORNERS WAS THE EXISTING WEBER COUNTY SURVEY MONUMENTATION SURROUNDING SECTION 28, T6N, R2W, SLB&M.
THE BASIS OF BEARING IS THE NORTH SECTION LINE OF THE NORTHEAST QUARTER OF SECTION 28 WHICH BEARS SOUTH 89°14'58" EAST, UTAH NORTH, STATE PLANE, CALCULATED N.A.D.83 BEARING.

SURVEYOR'S CERTIFICATE

I, ROGER C. SLADE, DO HEREBY CERTIFY THAT I AM A REGISTERED PROFESSIONAL LAND SURVEYOR IN THE STATE OF UTAH IN ACCORDANCE WITH TITLE 58, CHAPTER 22, PROFESSIONAL ENGINEERS AND PROFESSIONAL LAND SURVEYORS ACT; AND BY THE AUTHORITY OF THE OWNERS, I HAVE COMPLETED A SURVEY OF THE PROPERTY DESCRIBED AND SHOWN HEREON THIS PLAT IN ACCORDANCE WITH SECTION 17-23-17 AND HAVE VERIFIED ALL MEASUREMENTS, AND THAT THE SAME HAS BEEN SURVEYED AND MONUMENTS HAVE BEEN LOCATED AND/OR PLACED ON THE GROUND AS REPRESENTED ON THE PLAT HEREON.
SIGNED THIS 26TH DAY OF APRIL, 2021.

ROGER C. SLADE, PLS
UTAH LAND SURVEYOR LICENCE NO. 11386802

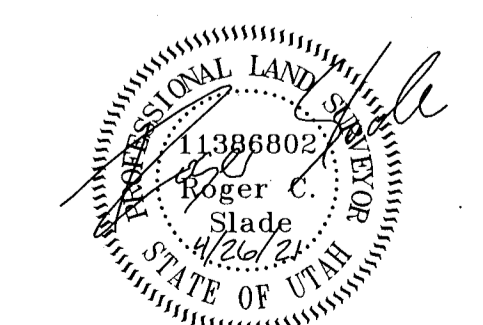

ACCESS EASEMENT NO. 1

AN ACCESS EASEMENT FOR INGRESS AND EGRESS SITUATED IN THE NORTHWEST QUARTER OF SECTION 28, TOWNSHIP 6 NORTH, RANGE 2 WEST OF THE SALT LAKE BASE AND MERIDIAN. MORE PARTICULARLY DESCRIBED AS FOLLOWS:
BEGINNING AT A POINT ON THE SOUTH RIGHT-OF-WAY LINE OF 1800 SOUTH STREET LOCATED 515.33 FEET NORTH 89°07'56" WEST AND 33.00 FEET SOUTH 00°52'04" WEST FROM THE NORTH QUARTER CORNER OF SAID SECTION 28 (BASIS OF BEARING IS THE NORTH LINE OF THE NORTHEAST QUARTER OF SECTION 28 WHICH BEARS SOUTH 89°14'58" EAST);
RUNNING THENCE SOUTH 02°53'07" WEST 113.61 FEET; THENCE SOUTH 62°00'56" WEST 14.31 FEET; THENCE NORTH 03°15'41" EAST 120.55 FEET TO SAID SOUTH RIGHT-OF-WAY LINE; THENCE SOUTH 89°07'56" EAST 11.50 FEET ALONG SAID SOUTH RIGHT-OF-WAY LINE TO THE POINT OF BEGINNING.

ACCESS EASEMENT NO. 2

AN ACCESS EASEMENT FOR INGRESS AND EGRESS SITUATED IN THE NORTHWEST QUARTER OF SECTION 28, TOWNSHIP 6 NORTH, RANGE 2 WEST OF THE SALT LAKE BASE AND MERIDIAN. MORE PARTICULARLY DESCRIBED AS FOLLOWS:
BEGINNING AT A POINT ON THE SOUTH RIGHT-OF-WAY LINE OF 1800 SOUTH STREET LOCATED 515.33 FEET NORTH 89°07'56" WEST AND 33.00 FEET SOUTH 00°52'04" WEST FROM THE NORTH QUARTER CORNER OF SAID SECTION 28 (BASIS OF BEARING IS THE NORTH LINE OF THE NORTHEAST QUARTER OF SECTION 28 WHICH BEARS SOUTH 89°14'58" EAST);
RUNNING THENCE SOUTH 89°07'56" EAST 18.53 FEET ALONG SAID SOUTH RIGHT-OF-WAY LINE; THENCE SOUTH 03°15'41" WEST 137.11 FEET; THENCE NORTH 89°08'56" WEST 41.81 FEET; THENCE SOUTH 00°52'04" WEST 24.36 FEET; THENCE SOUTH 60°38'06" WEST 29.95 FEET; THENCE NORTH 00°52'04" EAST 34.86 FEET; THENCE NORTH 62°00'56" EAST 58.09 FEET; THENCE NORTH 02°53'07" EAST 113.61 FEET TO THE POINT OF BEGINNING.

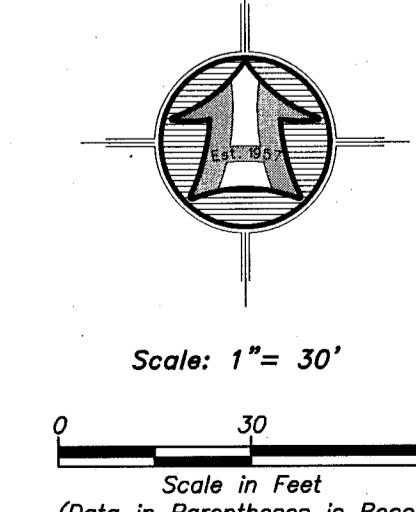

LEGEND

- SUBJECT PROPERTY LINE
- - - ADJOINING PROPERTY LINE
- - - PREVIOUS PROPERTY LINE
- - - CENTERLINE
- - - FENCE LINE
- ⊕ STREET MONUMENT
- FOUND SURVEY MARKER
- ⊙ SET 5/8"X24" REBAR WITH CAP
- ⊙ SECTION CORNER

BOUNDARY ADJUSTMENT & PROPERTY SURVEY FOR

BOB ROPELATO
3945 WEST 1800 SOUTH
WEBER COUNTY, UTAH
A PART OF THE NORTHWEST QUARTER OF SECTION 28
TOWNSHIP 6 NORTH, RANGE 2 WEST, S.L.B.&M.

HANSEN & ASSOCIATES, INC.
Consulting Engineers and Land Surveyors
538 North Main Street, Brigham, Utah 84302
Visit us at www.hansen.net
Lagan
Brigham City
(435) 723-3491 (801) 399-4905 (435) 725-8272
Celebrating over 60 Years of Business

No.	
Date	
By	
Revision	

Drawn By: BS Date: 04/26/2021
Designed By: Jsh
Checked By: Jsh
Approved By: Jsh
Scale: 1" = 30'
Drawing File: 21-3-24-18.dwg
JOB NUMBER: 21-3-24

RECEIVED
MAY 10 2021
BY: 6852

Sheet
1
of
1
Sheets