

BOUNDARY DESCRIPTION

ALL OF LOT 294, LAKEVIEW HEIGHTS SUBDIVISION, PHASE 4-A, PRUD, NORTH OGDEN CITY, WEBER COUNTY, UTAH.

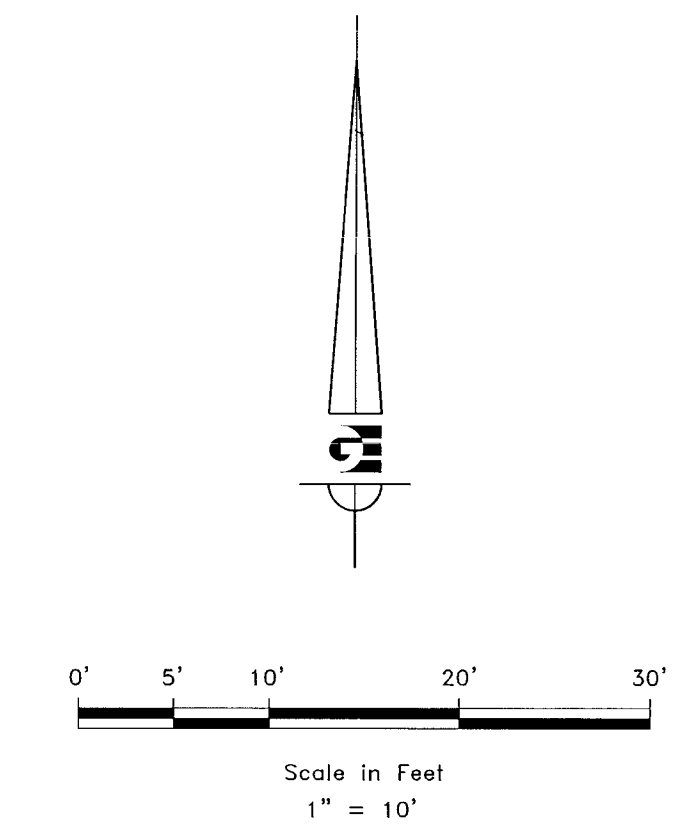

LEGEND

- STREET CENTERLINE MONUMENT AS NOTED
- SET 24" REBAR AND CAP MARKED GARDNER ENGINEERING
- SUBJECT PROPERTY BOUNDARY
- ADJACENT PARCEL
- SECTION LINE
- EASEMENT
- EXISTING FENCE LINE

NARRATIVE

THE PURPOSE OF THIS SURVEY WAS TO ESTABLISH AND SET THE PROPERTY CORNERS OF THE PARCEL AS SHOWN AND DESCRIBED HEREON. THE SURVEY WAS ORDERED BY GARRET Phipps. THE BASIS OF BEARING IS THE LINE BETWEEN STREET CENTERLINE MONUMENTS FOUND AT THE INTERSECTION OF 3475 NORTH AND 425 EAST AND THE INTERSECTION OF 3475 NORTH AND 450 EAST, WHICH BEARS SOUTH 79°09'49" WEST, WEBER COUNTY, UTAH NORTH, NAD 83 STATE PLANE GRID BEARING. THE BOUNDARY WAS DETERMINED BY WARRANTY DEED RECORDED AS ENTRY NUMBER 2945898. THE DEDICATED PLATS OF LAKEVIEW HEIGHTS SUBDIVISION - PHASE 4A WAS ALSO USED TO DETERMINE BOUNDARY LOCATION ALONG WITH THE FOUND MONUMENTS AS SHOWN AND DESCRIBED HEREON.

SURVEYOR'S CERTIFICATE

I, KLINT H. WHITNEY, DO HEREBY CERTIFY THAT I AM A LICENSED PROFESSIONAL LAND SURVEYOR IN THE STATE OF UTAH AND THAT I HOLD CERTIFICATE NO. 8227228 IN ACCORDANCE WITH TITLE 58, CHAPTER 22, OF THE PROFESSIONAL ENGINEERS AND LAND SURVEYORS ACT. I FURTHER CERTIFY THAT BY AUTHORITY OF THE OWNERS I HAVE COMPLETED A SURVEY OF THE PROPERTY DESCRIBED ON THIS RECORD OF SURVEY PLAT IN ACCORDANCE WITH SECTION 17-23-20 AND HAVE VERIFIED ALL MEASUREMENTS, THAT THE REFERENCE MONUMENTS SHOWN ON THIS RECORD OF SURVEY PLAT ARE LOCATED AS INDICATED AND ARE SUFFICIENT TO RETRACE OR REESTABLISH THIS SURVEY; AND THAT THE INFORMATION SHOWN HEREIN IS SUFFICIENT TO ACCURATELY ESTABLISH THE LATERAL BOUNDARIES OF THE HEREIN DESCRIBED TRACT OF REAL PROPERTY.

SIGNED THIS 25<sup>TH</sup> DAY OF MAY, 2021.

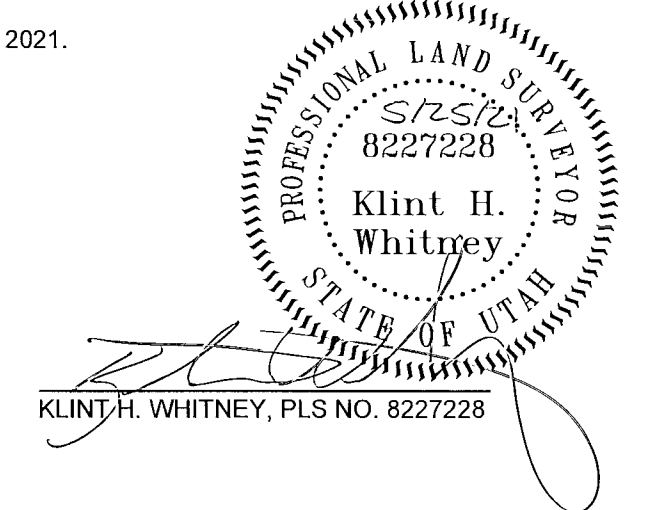

RECEIVED  
MAY 26 2021  
BY: 6881

REVISIONS	DATE	DESCRIPTION

SCALE: 1:10 XREF  
DATE: 3/17/21  
DESIGN: KHW  
DRAWN: KHW  
CHECKED: KHW  
DWG: R:\801-MEC SURVEY\134-GARRETT Phipps SURVEY\0304021 Phipps.DWG

PROPERTY SURVEY FOR GARRETT Phipps  
435 EAST 3475 NORTH, NORTH OGDEN, UTAH  
LOCATED IN THE SOUTHEAST QUARTER OF SECTION 20,  
TOWNSHIP 7 NORTH, RANGE 1 WEST, S.L.B. AND M.

**GARDNER ENGINEERING**  
CIVIL, LAND PLANNING  
MUNICIPAL, LAND SURVEYING  
5150 SOUTH 975 EAST OGDEN, UT  
OFFICE: 801-476-0202 FAX: 801-476-0066

S1  
1