

PARCEL 120820033 BOUNDARY DESCRIPTION
 ALL OF LOT 11 AND THE NORTH 1/2 OF LOT 12, BLOCK 4, MONTEREY ADDITION, OGDEN CITY, WEBER COUNTY, UTAH.

PARCEL 120820034 BOUNDARY DESCRIPTION
 THE SOUTH 1/2 OF LOT 12 AND ALL OF LOT 13, BLOCK 4, MONTEREY ADDITION, OGDEN CITY, WEBER COUNTY, UTAH.

PARCEL 120820029 BOUNDARY DESCRIPTION
 ALL OF LOT 8, BLOCK 4, MONTEREY ADDITION, OGDEN CITY, WEBER COUNTY, UTAH.

PARCEL 120820028 BOUNDARY DESCRIPTION
 ALL OF LOTS 5 TO 7, INCLUSIVE BLOCK 4, MONTEREY ADDITION, OGDEN CITY, WEBER COUNTY, UTAH.

RECEIVED
 MAY 26 2021
 BY: 6884

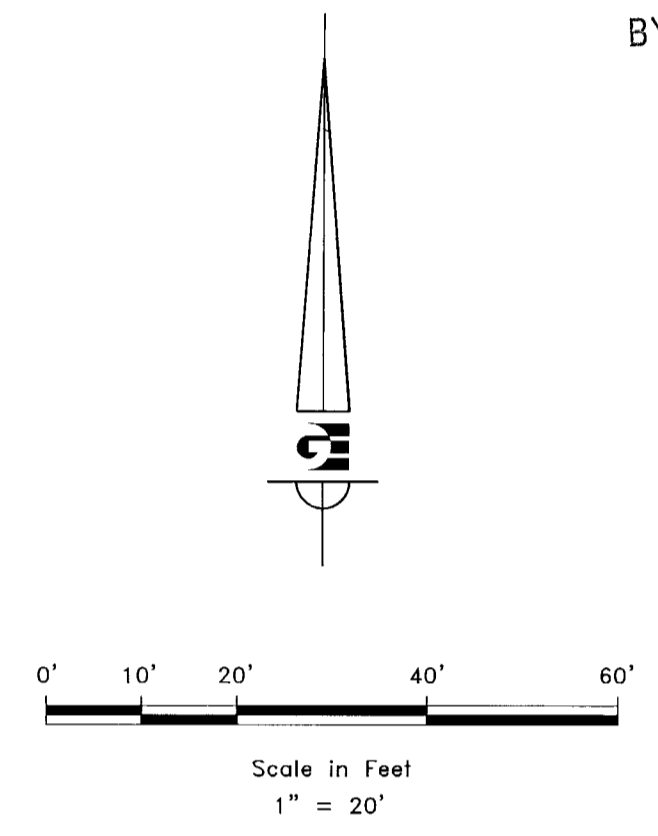

- LEGEND**
- ◆ OGDEN CITY SURVEY MONUMENT AS NOTED
 - SET 24" REBAR AND CAP MARKED GARDNER ENGINEERING
 - SUBJECT PROPERTY BOUNDARY
 - LOT LINE
 - - - ADJACENT PARCEL
 - - - SECTION LINE
 - - - EASEMENT
 - - - EXISTING FENCE LINE

NARRATIVE

THE PURPOSE OF THIS SURVEY WAS TO ESTABLISH AND SET THE PROPERTY CORNERS OF THE PARCEL AS SHOWN AND DESCRIBED HEREON. THE SURVEY WAS ORDERED BY SY IMLAY. THE BASIS OF BEARING IS THE CENTERLINE OF WASHINGTON BOULEVARD BETWEEN THE INTERSECTIONS OF 600 SOUTH AND 500 SOUTH, WHICH BEARS NORTH 01°10'58" EAST, WEBER COUNTY, UTAH NORTH, NAD 83 STATE PLANE GRID BEARING. THE BOUNDARY WAS DETERMINED BY WARRANTY DEED RECORDED AS ENTRY NUMBER 2893824, 2793512, 2779547, 2893824 AND DEEDS OF ADJOINING PROPERTY OWNERS. RECORD OF SURVEY NUMBERS 2886, AND THE DEDICATED PLATS OF MONTEREY ADDITION WERE ALSO USED TO DETERMINE BOUNDARY LOCATION ALONG WITH THE FOUND MONUMENTS AS SHOWN AND DESCRIBED HEREON.

SURVEYOR'S CERTIFICATE

I, KLINT H. WHITNEY, DO HEREBY CERTIFY THAT I AM A LICENSED PROFESSIONAL LAND SURVEYOR IN THE STATE OF UTAH AND THAT I HOLD CERTIFICATE NO. 8227228 IN ACCORDANCE WITH TITLE 58, CHAPTER 22, OF THE PROFESSIONAL ENGINEERS AND LAND SURVEYORS ACT. I FURTHER CERTIFY THAT BY AUTHORITY OF THE OWNERS I HAVE COMPLETED A SURVEY OF THE PROPERTY DESCRIBED ON THIS RECORD OF SURVEY PLAT IN ACCORDANCE WITH SECTION 17-23-20 AND HAVE VERIFIED ALL MEASUREMENTS; THAT THE REFERENCE MONUMENTS SHOWN ON THIS RECORD OF SURVEY PLAT ARE LOCATED AS INDICATED AND ARE SUFFICIENT TO RETRACE OR REESTABLISH THIS SURVEY; AND THAT THE INFORMATION SHOWN HEREIN IS SUFFICIENT TO ACCURATELY ESTABLISH THE LATERAL BOUNDARIES OF THE HEREIN DESCRIBED TRACT OF REAL PROPERTY.

SIGNED THIS 25th DAY OF May, 2021.

PROFESSIONAL LAND SURVEYOR
 STATE OF UTAH
 Klint H. Whitney
 8227228
 Klint H. Whitney, PLS NO. 8227228

REVISIONS	DATE	DESCRIPTION

SCALE: 1:20 X REF
 DATE: 5/24/2021
 DESIGN: _____
 DRAWN: KHW
 CHECKED: KHW
 DWG. NO.: R-2021-MISC SURVEY 1113 - SY IMLAY SURVEY 0055 IMLAY.DWG

PROPERTY SURVEY FOR SY IMLAY
 543 WASHINGTON BOULEVARD, OGDEN UTAH
 LOCATED IN THE SOUTHEAST QUARTER OF SECTION 28,
 TOWNSHIP 7 NORTH, RANGE 1 WEST, S.L.B. AND M.

GARDNER ENGINEERING
 CIVIL-LAND PLANNING
 MUNICIPAL-LAND SURVEYING
 5150 SOUTH 375 EAST OGDEN, UT
 OFFICE: 801-476-0202 FAX: 801-476-0066

S1
 1