

Narrative

The purpose of this survey was to establish and set the property corners of the parcel as shown and described hereon. The survey was ordered by Martha and Roberto Ponce. The control used to establish the property corners was the existing Ogden City Survey Monumentation within the Townside Park Subdivision and along 6th Street. There are encroachments on the West line of the property as shown hereon. The basis of bearing is the Centerline of said 6th Street from the monument at Adams Ave. to the Monument at Porter Ave. which bears South 88°49'42" East, Utah North, State Plane, Calculated N.A.D.83 Bearing. South 89°09'45" East per said Townside Park Subdivision.

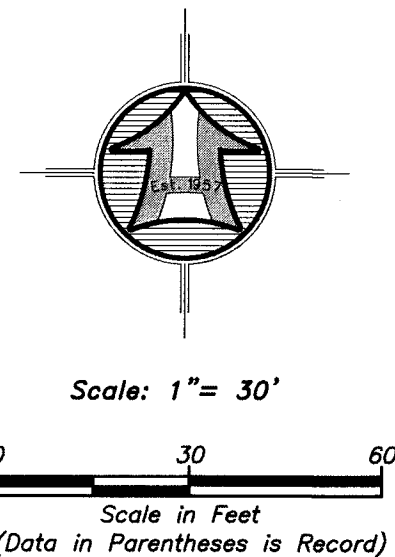

BOUNDARY DESCRIPTION

ALL OF LOT 24, TOWNSIDE PARK SUBDIVISION, OGDEN CITY, WEBER COUNTY, UTAH SURVEY.

- LEGEND**
- Subject Property Line
 - - - - - Adjoining Property Line
 - - - - - Previous Property Line
 - Centerline
 - - - - - Fence Line (Wire)
 - - - - - Fence Line (wood or Vinyl)
 - Street Monument
 - Found rebar set by others
 - Set 5/8"x24" Rebar With Cap
 - Section Corner

SURVEYOR'S CERTIFICATE

I, K. Greg Hansen, do hereby certify that I am a Registered Professional Land Surveyor in the State of Utah in accordance with Title 58, Chapter 22, Professional Engineers and Professional Land Surveyors Act; and by the authority of the owners, I have completed a survey of the property described and shown hereon this plat in accordance with Section 17-23-17 and have verified all measurements, and that the same has been surveyed and monuments have been located and/or Placed on the ground as represented on the plat hereon.

Signed this 28th day of April, 2021.

K. Greg Hansen PLS
Utah Land Surveyor License No. 167819

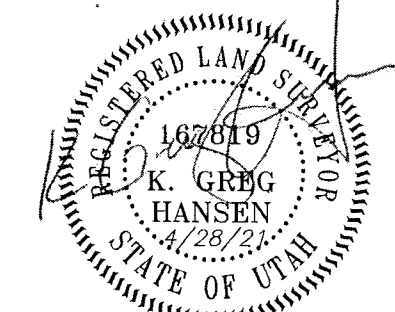

RECEIVED
JUN 03 2021
BY: G890

Property Survey for
Roberto T. Ponce
545 6th Street
Ogden City, Weber County, Utah
A Part of the Southwest Quarter of Section 16,
Township 6 North, Range 1 West, S.L.B.&M.

Sheet
1
of
1
Sheets

Drawn By: Date: 04/20/21
Checked By:
Approved By:
Scale: 1" = 30'
Drawing File: 21-3-92 v18
JOB NUMBER: 21-3-92

HANSEN & ASSOCIATES, INC.
Consulting Engineers and Land Surveyors
538 North Main Street, Brigham, Utah 84302
Visit us at www.hansen.net
Logan Ogden
(435) 723-3491 (801) 398-4905 (435) 752-9272
Celebrating over 60 Years of Business