

NARRATIVE

THE PURPOSE OF THIS SURVEY WAS TO ESTABLISH AND SET THE PROPERTY CORNERS AS SHOWN AND DESCRIBED HEREON. THE SURVEY WAS ORDERED BY NICK WEAVER FOR RW CUSTOM. THE CONTROL USED TO ESTABLISH THE PROPERTY CORNERS WAS THE OFFICIAL PLAT OF SPRING MOUNTAIN SUBDIVISION NO. 2, ENTRY NO. 2069363 SITUATED IN THE NORTHEAST QUARTER OF SECTION 30, T7N, R1E, S.L.B.&M.

THE BASIS OF BEARING IS THE WEST LINE OF LOT 7, SPRING MOUNTAIN SUBDIVISION NO. 2 BETWEEN AN EXISTING OLD REBAR AT THE SOUTHWEST CORNER OF SAID LOT 7 TO AN EXISTING GREAT BASIN REBAR & CAP AT THE NORTHWEST CORNER OF SAID LOT 7 WHICH BEARS NORTH 0°10'55" WEST, AS SHOWN ON THE OFFICIAL PLAT OF SAID SPRING MOUNTAIN SUBDIVISION NO. 2.

RECORD BOUNDARY DESCRIPTION

ALL OF LOT 7, SPRING MOUNTAIN SUBDIVISION NO. 2, WEBER COUNTY, UTAH.

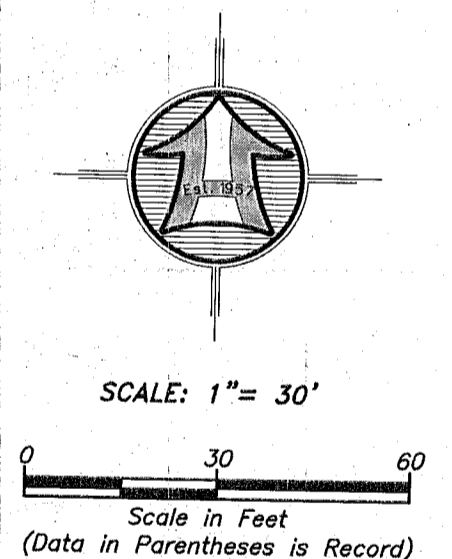

- LEGEND**
- SUBJECT PROPERTY LINE
 - - - SUBDIVISION BOUNDARY
 - - - ADJOINING PROPERTY LINE
 - FOUND REBAR SET BY OTHERS
 - SET 5/8"x24" REBAR WITH CAP
 - ◇ SECTION CORNER

RECEIVED
SEP 01 2021
BY: UAGZ

SURVEYOR'S CERTIFICATE

I, ROGER C. SLADE, DO HEREBY CERTIFY THAT I AM A REGISTERED PROFESSIONAL LAND SURVEYOR IN THE STATE OF UTAH IN ACCORDANCE WITH TITLE 58, CHAPTER 22, PROFESSIONAL ENGINEERS AND PROFESSIONAL LAND SURVEYORS ACTS AND BY THE AUTHORITY OF THE OWNERS, I HAVE COMPLETED A SURVEY OF THE PROPERTY DESCRIBED AND SHOWN HEREON THIS PLAT IN ACCORDANCE WITH SECTION 17-23-17 AND HAVE VERIFIED ALL MEASUREMENTS, AND THAT THE SAME HAS BEEN SURVEYED AND MONUMENTS HAVE BEEN LOCATED AND/OR PLACED ON THE GROUND AS REPRESENTED ON THE PLAT HEREON.

SIGNED THIS 18TH DAY OF AUGUST, 2021.

ROGER C. SLADE, PLS
UTAH LAND SURVEYOR LICENCE NO. 11386802

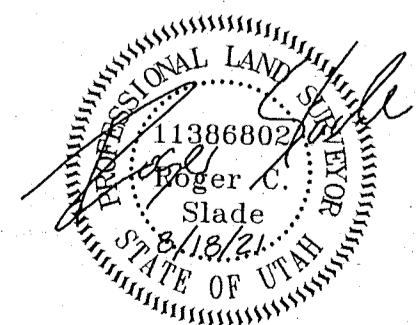

(C1)
Δ = 12'55"58"
R = 841.00'
L = 189.83'
LC = 189.43'
S 4°25'25" W

<p>Drawn By: RS Date: 08/18/2021</p> <p>Checked By: MP</p> <p>Approved By: [Signature]</p> <p>Scale: 1" = 30'</p> <p>Drawing File: 21-3-1386802.dwg</p> <p>JOB NUMBER: 21-3-138</p>	<p>No. _____</p> <p>Date _____</p> <p>By _____</p> <p>Revision _____</p>
<p>HANSEN & ASSOCIATES, INC. Consulting Engineers and Land Surveyors 538 North Main Street, Brigham, Utah 84302 Visit us at www.hales.net Logan, Utah (435) 725-9441 (801) 388-4605 (435) 752-8272 Celebrating over 60 Years of Business</p>	
<p>PROPERTY SURVEY FOR RW CUSTOM INC. 3377 NORTH 2900 EAST WEBER COUNTY, UTAH A PART OF THE NORTHEAST QUARTER OF SECTION 30 TOWNSHIP 7 NORTH, RANGE 1 EAST, S.L.B.&M.</p>	
<p>Sheet 1 of 1 Sheets</p>	