

Parcel No. 1
 A PART OF THE NORTHWEST QUARTER AND NORTHEAST QUARTER OF SECTION 4, TOWNSHIP 6 NORTH, RANGE 1 WEST OF THE SALT LAKE BASE AND MERIDIAN.

BEGINNING AT THE NORTHEAST CORNER OF LOT 9, MOUNTAIN MEADOW SUBDIVISION, NORTH OGDEN CITY, UTAH SURVEY, FILED AS ENTRY NO. 985423 IN THE FILES OF THE WEBER COUNTY RECORDER, SAID POINT BEING ON THE SOUTH BOUNDARY LINE OF GREENFIELD SUBDIVISION PHASE 1 FILED AS ENTRY NO. 924837 IN THE FILES OF THE WEBER COUNTY RECORDER LOCATED 177.45 FEET SOUTH 00°30'50" WEST ALONG THE EAST LINE OF SAID NORTHWEST QUARTER AND 242.68 FEET SOUTH 85°48'43" WEST AND 78.20 FEET SOUTH 88°33'00" WEST FROM THE NORTH QUARTER CORNER OF SAID SECTION 4;

RUNNING THENCE ALONG THE SOUTH BOUNDARY LINE OF SAID GREENFIELD SUBDIVISION THE FOLLOWING SIX (6) COURSES; (1) NORTH 88°33'00" EAST (NORTH 88°11'00" EAST BY RECORD) 78.20 FEET; (2) NORTH 85°57'17" EAST (NORTH 85°56'50" EAST BY RECORD) 242.82 FEET; (3) SOUTH 80°48'28" EAST (SOUTH 81°10'28" EAST BY RECORD) 47.62 FEET; (4) NORTH 70°36'03" EAST (NORTH 70°14'03" EAST BY RECORD) 94.82 FEET; (5) NORTH 34°41'35" EAST (NORTH 34°19'35" EAST BY RECORD) 31.05 FEET; AND (6) NORTH 80°15'15" EAST (NORTH 79°53'15" EAST BY RECORD) 89.03 FEET; THENCE SOUTH 64°39'46" EAST 13.07 FEET TO THE CENTERLINE OF THE NORTH OGDEN CANAL; THENCE ALONG SAID CENTERLINE THE FOLLOWING SEVEN (7) COURSES; (1) SOUTH 34°01'47" WEST 67.79 FEET; (2) SOUTH 04°47'55" EAST 45.82 FEET; (3) SOUTH 27°03'45" EAST 82.24 FEET; (4) SOUTH 29°18'45" EAST 47.01 FEET; (5) SOUTH 21°30'31" EAST 45.30 FEET; (6) SOUTH 41°14'45" EAST 34.51 FEET; AND (7) SOUTH 52°48'08" EAST 21.65 FEET; THENCE SOUTH 89°58'08" WEST 340.79 FEET TO A POINT ON THE PROJECTION OF THE WEST BOUNDARY LINE OF STONEHOUSE SUBDIVISION BEING A POINT 2.90 FEET EAST OF THE EAST LINE OF SAID NORTHWEST QUARTER; THENCE ALONG SAID PROJECTION LINE SOUTH 00°30'50" WEST (SOUTH 00°15'00" WEST BY RECORD) 179.47 FEET TO THE NORTH BOUNDARY LINE OF THE PAUL A. MACKLEY PROPERTY, TAX ID. NO. 11-004-0079; THENCE ALONG SAID NORTH BOUNDARY LINE NORTH 89°23'00" WEST 241.08 FEET (NORTH 89°45' EAST 240 FEET BY RECORD) TO THE NORTHEAST CORNER OF LOT 4 OF SAID MOUNTAIN MEADOW SUBDIVISION; THENCE NORTH 00°37'00" EAST (NORTH 00°15' EAST BY RECORD) 167.63 FEET ALONG THE EAST BOUNDARY LINE OF SAID MOUNTAIN MEADOW SUBDIVISION TO THE NORTHEAST CORNER OF LOT 5 OF SAID MOUNTAIN MEADOW SUBDIVISION BEING THE SOUTHEAST CORNER OF THE BRANDI LONG AND COLE VEIBELL PROPERTY, TAX ID. NO. 11-205-0007; THENCE ALONG SAID LONG AND VEIBELL BOUNDARY LINE THE FOLLOWING TWO (2) COURSES; (1) NORTH 01°52'16" EAST 64.76 FEET (NORTH 62.47 FEET BY RECORD); AND (2) NORTH 89°23'00" WEST (WEST BY RECORD) 79.59 FEET TO THE EAST BOUNDARY LINE OF SAID MOUNTAIN MEADOW SUBDIVISION; THENCE NORTH 00°37'00" EAST (NORTH 00°15' EAST BY RECORD) 162.51 FEET ALONG SAID EAST BOUNDARY LINE TO THE POINT OF BEGINNING. CONTAINING 179,500 SQUARE FEET OR 4.121 ACRES.

Parcel No. 2
 A PART OF THE NORTHEAST QUARTER OF SECTION 4, TOWNSHIP 6 NORTH, RANGE 1 WEST OF THE SALT LAKE BASE AND MERIDIAN.

BEGINNING AT A POINT LOCATED 415.12 FEET SOUTH 00°30'50" WEST ALONG THE EAST LINE OF SAID NORTHWEST QUARTER AND 180.90 FEET NORTH 89°58'08" EAST FROM THE NORTH QUARTER CORNER OF SAID SECTION 4;

RUNNING THENCE SOUTH 00°30'56" WEST 126.87 FEET TO THE NORTH BOUNDARY LINE OF STONEHOUSE SUBDIVISION FILED AS ENTRY NO. 2123488 IN THE FILES OF THE WEBER COUNTY RECORDER; THENCE ALONG SAID NORTH BOUNDARY LINE SOUTH 88°45'01" WEST (SOUTH 89°29'05" WEST BY RECORD) 178.08 FEET TO A POINT 2.90 FEET EAST OF THE WEST LINE OF SAID NORTHWEST QUARTER; THENCE NORTH 00°30'50" EAST 130.66 FEET; THENCE NORTH 89°58'08" EAST 178.00 FEET TO THE POINT OF BEGINNING. CONTAINING 22,920 SQUARE FEET OR 0.526 ACRES.

Parcel No. 3
 A PART OF THE NORTHEAST QUARTER OF SECTION 4, TOWNSHIP 6 NORTH, RANGE 1 WEST OF THE SALT LAKE BASE AND MERIDIAN.

BEGINNING AT A POINT LOCATED 415.12 FEET SOUTH 00°30'50" WEST ALONG THE EAST LINE OF SAID NORTHWEST QUARTER AND 180.90 FEET NORTH 89°58'08" EAST FROM THE NORTH QUARTER CORNER OF SAID SECTION 4;

RUNNING THENCE NORTH 89°58'08" EAST 162.79 FEET TO THE CENTERLINE OF THE NORTH OGDEN CANAL; THENCE ALONG SAID CENTERLINE THE FOLLOWING SEVEN (7) COURSES; (1) SOUTH 51°02'27" EAST 38.41 FEET; (2) SOUTH 44°21'07" EAST 17.13 FEET; (3) SOUTH 30°11'29" EAST 9.11 FEET; (4) SOUTH 11°02'45" EAST 17.71 FEET; (5) SOUTH 12°48'53" WEST 33.64 FEET; (6) SOUTH 35°34'03" WEST 23.90 FEET; AND (7) SOUTH 44°12'49" WEST 12.58 FEET TO THE NORTHEAST CORNER OF STONEHOUSE SUBDIVISION FILED AS ENTRY NO. 2123488 IN THE FILES OF THE WEBER COUNTY RECORDER; THENCE SOUTH 88°45'01" WEST (SOUTH 88°29'05" WEST BY RECORD) 183.65 FEET ALONG THE NORTH LINE OF SAID STONEFIELD SUBDIVISION; THENCE NORTH 00°30'56" EAST 126.87 FEET TO THE POINT OF BEGINNING. CONTAINING 24,841 SQUARE FEET OR 0.570 ACRES.

Narrative
 The Purpose of this survey was to prepare this Lot Line Amendment as shown and described hereon. This Survey was ordered by Paul Mackley. This Lot Line Amendment is redefining the boundaries of parcels Tax ID. No. 11-003-0066, 11-004-0103 AND 11-004-0085. The control used to establish the property corners was the Greenfield Subd. Ph. 1 to the north, Mountain Meadow Subd. to the west and Stonehouse Subd. to the south along with the existing Weber County Survey Monumentation surrounding Section 4, Township 6 North, Range 1 West, S.L.B.&M. The basis of bearing is the North line of the Northeast Quarter of said Section which bears North 89°42'01" West, Utah North, State Plane, Calculated N.A.D.83 Bearing.

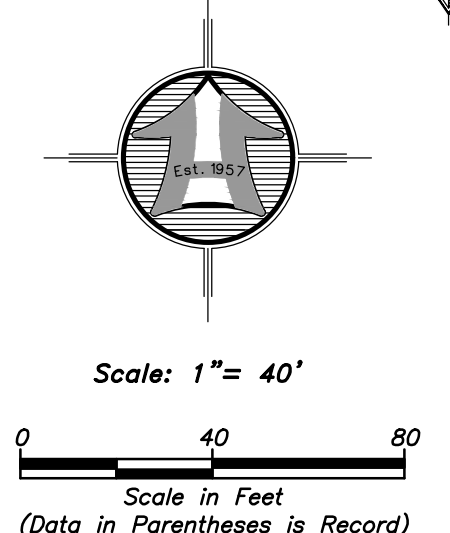

- LEGEND**
- Subject Property Line
 - - - Adjoining Property Line
 - Interior Lot Lines
 - Centerline
 - - - Field Separation Line
 - - - Fence Line (Wire)
 - - - Fence Line (wood or Vinyl)
 - Street Monument
 - Found rebar set by others
 - Set 5/8"x24" Rebar With Cap
 - Section Corner

RECEIVED
 SEP 13 2021
 FILE # 6970

SURVEYOR'S CERTIFICATE
 I, K. Greg Hansen, do hereby certify that I am a Registered Professional Land Surveyor in the State of Utah in accordance with Title 58, Chapter 22, Professional Engineers and Professional Land Surveyors Act; and by the authority of the owners, I have completed a survey of the property described and shown hereon this plat in accordance with Section 17-23-17 and have verified all measurements, and that the same has been surveyed and monuments have been located and/or Placed on the ground as represented on the plat hereon.

Signed this 8th day of September, 2021.
 K. Greg Hansen
 Utah Land Surveyor Licence No. 167819



Blvd. 725 East
 1750 Monroe

HANSEN & ASSOCIATES, INC.
 Consulting Engineers and Land Surveyors
 538 North Main Street, Brigham, Utah 84302
 Visit us at www.hailes.net
 Logan
 Ogden
 (435) 723-3491 (801) 399-4905 (435) 952-8272
 Celebrating over 60 Years of Business

HAI

Drawn By: kgh Date: 07/16/19
 Designed By: rs
 Checked By: rs
 Approved By: rs
 Scale: 1" = 40'
 Drawing File: 19-122 v15 lotlineamd
 JOB NUMBER: 19-122

Lot Line Amendment Survey For
Paul A. Mackley
 730 East 1750 North
 North Ogden City, Weber County, Utah
 A Part of the Northwest & Northeast Quarters of Section 4,
 Township 6 North, Range 1 West, S.L.B.&M.

Sheet
1
 of
1
 Sheets