



BOUNDARY DESCRIPTION PARCEL 070300002

ALL OF LOT 2, EDGEWOOD HILLS ADDITION NO. 3, IN SOUTH OGDEN CITY, WEBER COUNTY, UTAH

BOUNDARY DESCRIPTION PARCEL 070300029

PART OF LOT 21, EDGEWOOD HILLS ADDITION NO. 3: BEGINNING AT THE SOUTHEAST CORNER OF SAID LOT 2, AND RUNNING THENCE SOUTH 2 WEST TO THE SOUTH LINE OF SAID LOT 21; THENCE NORTH 43°54' WEST TO THE NORTHWEST CORNER OF SAID LOT 21; THENCE SOUTH 85°30' EAST TO THE PLACE OF BEGINNING.

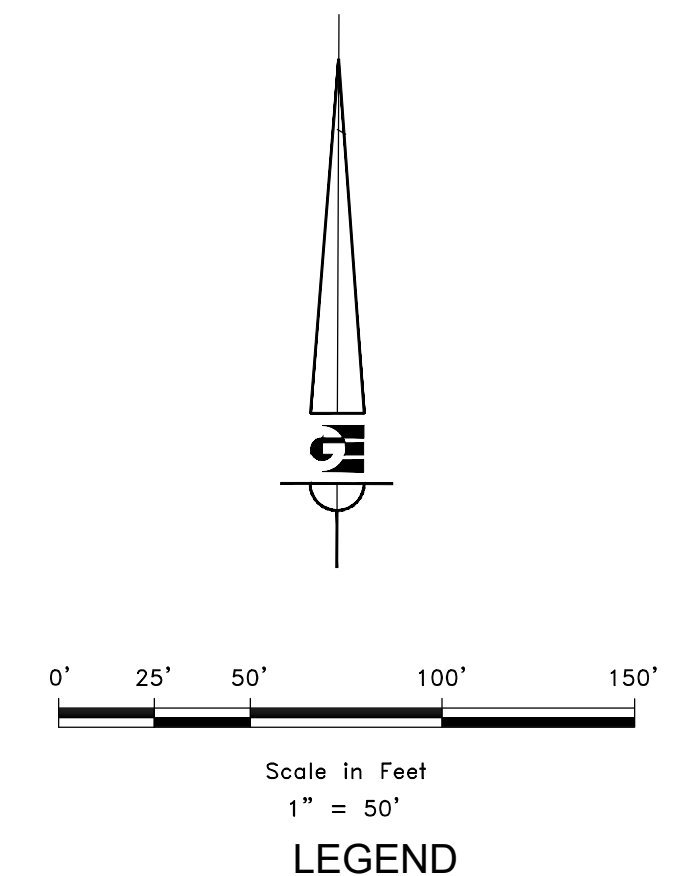

NARRATIVE

THE PURPOSE OF THIS SURVEY WAS TO ESTABLISH AND SET THE PROPERTY CORNERS OF THE PROPERTY AS SHOWN AND DESCRIBED HEREON. RECORD BEARINGS HAVE BEEN ROTATED TO UTAH NORTH, NAD 83, STATE PLANE GRID BEARINGS AS SHOWN HEREON. THE BASIS OF BEARING IS THE WEST LINE OF THE NORTHWEST QUARTER OF SECTION 16, TOWNSHIP 5 NORTH, RANGE 1 WEST OF THE SALT LAKE BASE AND MERIDIAN WHICH BEARS SOUTH 00°52'40"W WEST WEBER COUNTY, UTAH NORTH, NAD 83 STATE PLANE GRID BEARING. OCCUPATION WAS MEASURED THROUGHOUT THE ENTIRETY OF THE EDGEWOOD HILLS ADDITION NUMBER 2 AND 3 AND OTHER ADJOINING DEVELOPMENTS AS SHOWN HEREON. THE SURVEY WAS ORDERED BY ROSE LITTLE. THE BOUNDARY WAS ESTABLISHED BY RECORD OF SURVEY RECORDED AS SURVEY NUMBER 6366 PREPARED BY ENTELLUS AND RECORD OF SURVEY NUMBER 5801 ALONG WITH THE FOUND MONUMENTATION AS SHOWN HEREON.

RECEIVED
SEPT 15 2021
FILE # 6975

SURVEYOR'S CERTIFICATE

I, KLINT H. WHITNEY, DO HEREBY CERTIFY THAT I AM A LICENSED PROFESSIONAL LAND SURVEYOR IN THE STATE OF UTAH AND THAT I HOLD CERTIFICATE NO. 8227228 IN ACCORDANCE WITH TITLE 58, CHAPTER 22, OF THE PROFESSIONAL ENGINEERS AND LAND SURVEYORS ACT; I FURTHER CERTIFY THAT BY AUTHORITY OF THE OWNERS I HAVE COMPLETED A SURVEY OF THE PROPERTY DESCRIBED ON THIS RECORD OF SURVEY PLAT IN ACCORDANCE WITH SECTION 17-23-20 AND HAVE VERIFIED ALL MEASUREMENTS; THAT THE REFERENCE MONUMENTS SHOWN ON THIS RECORD OF SURVEY PLAT ARE LOCATED AS INDICATED AND ARE SUFFICIENT TO RETRACE OR REESTABLISH THIS SURVEY; AND THAT THE INFORMATION SHOWN HEREIN IS SUFFICIENT TO ACCURATELY ESTABLISH THE LATERAL BOUNDARIES OF THE HEREIN DESCRIBED TRACT OF REAL PROPERTY.

SIGNED THIS 3rd DAY OF SEPTEMBER, 2021.



REVISIONS	DATE	DESCRIPTION

SCALE: 1:50_XREF
DATE: 12/30/19
DESIGN: _____
DRAWN: KHW
CHECKED: KHW
DWG.: 162001 - MISC SURVEY 137 - ROSA LITTLE SURVEYORS & ENGINEERS

PROPERTY SURVEY FOR ROSE LITTLE
815 EAST 5050 SOUTH, SOUTH OGDEN, UTAH
LOCATED IN THE NORTHWEST QUARTER OF SECTION 16,
TOWNSHIP 5 NORTH, RANGE 1 WEST, S.L.B. AND M.

GARDNER ENGINEERING
CIVIL - LAND PLANNING
MUNICIPAL - LAND SURVEYING

5150 SOUTH 375 EAST OGDEN, UT
OFFICE: 801.476.0202 FAX: 801.476.0066