

RECORD PARCEL 210070006 BOUNDARY DESCRIPTION

PART OF THE SOUTHEAST QUARTER OF SECTION 7, TOWNSHIP 6 NORTH, RANGE 2 EAST, SALT LAKE BASE AND MERIDIAN, U.S. SURVEY, BEGINNING 10.02 CHAINS NORTH 18' EAST AND 1.77 CHAINS NORTH 86°53' WEST FROM SOUTHEAST CORNER SAID SOUTHEAST QUARTER OF SAID SECTION 7, RUNNING THENCE NORTH 86°53' WEST 605.41 FEET; THENCE NORTH 1°40' WEST 208.71 FEET; THENCE NORTH 86°53' WEST 208.71 FEET; THENCE NORTH 1°40' WEST 1061.79 FEET; THENCE SOUTH 86°53' EAST 10.56 CHAINS; THENCE SOUTH 2°10' EAST 19.27 CHAINS TO THE PLACE OF BEGINNING, CONTAINING 19.59 ACRES.

RECORD PARCEL 210070005 BOUNDARY DESCRIPTION

PART OF THE SOUTHEAST QUARTER OF SECTION 7, TOWNSHIP 6 NORTH, RANGE 2 EAST, SALT LAKE MERIDIAN, U.S. SURVEY, BEGINNING 10.02 CHAINS NORTH 18' EAST AND 12.59 CHAINS NORTH 86°53' WEST OF THE SOUTHEAST CORNER OF THE SOUTHEAST QUARTER OF SAID SECTION 7, THENCE 208.71 FEET NORTH 1°40' WEST; THENCE 208.71 FEET SOUTH 86°53' EAST; THENCE 208.71 FEET SOUTH 1°40' EAST; THENCE 208.71 FEET NORTH 86°53' WEST TO THE PLACE OF BEGINNING, CONTAINING 1 ACRE.

ADJUSTED PARCEL 210070005 BOUNDARY DESCRIPTION

PART OF THE SOUTHEAST QUARTER OF SECTION 7, TOWNSHIP 6 NORTH, RANGE 2 EAST, SALT LAKE BASE AND MERIDIAN, U.S. SURVEY, MORE PARTICULARLY DESCRIBED AS FOLLOWS. BEGINNING AT A POINT BEING LOCATED NORTH 0°27'07" EAST 666.09 FEET ALONG THE EAST LINE OF SAID SECTION AND NORTH 90°00'00" WEST 126.24 FEET AND NORTH 86°24'32" WEST 286.44 FEET, RUNNING THENCE NORTH 86°24'28" WEST 418.34 FEET TO THE EAST RIGHT-OF-WAY LINE OF 7800 EAST, THENCE NORTH 1°28'53" WEST 207.65 FEET; THENCE SOUTH 86°41'53" EAST 418.15 FEET; THENCE SOUTH 1°28'53" EAST 209.78 FEET TO THE POINT OF BEGINNING, CONTAINING 2.00 ACRES MORE OR LESS.

ADJUSTED AREA "A" BOUNDARY DESCRIPTION

PART OF THE SOUTHEAST QUARTER OF SECTION 7, TOWNSHIP 6 NORTH, RANGE 2 EAST, SALT LAKE BASE AND MERIDIAN, U.S. SURVEY, MORE PARTICULARLY DESCRIBED AS FOLLOWS. BEGINNING AT A POINT BEING LOCATED NORTH 0°27'07" EAST 666.09 FEET ALONG THE EAST LINE OF SAID SECTION AND NORTH 90°00'00" WEST 126.24 FEET AND NORTH 86°24'32" WEST 286.44 FEET, RUNNING THENCE NORTH 86°24'28" WEST 209.53 FEET; THENCE NORTH 1°28'53" WEST 208.71 FEET; THENCE SOUTH 86°41'53" EAST 209.44 FEET; THENCE SOUTH 1°28'53" EAST 209.78 FEET TO THE POINT OF BEGINNING, CONTAINING 1.00 ACRES MORE OR LESS.

ADJUSTED PARCEL 210070006 BOUNDARY DESCRIPTION

PART OF THE SOUTHEAST QUARTER OF SECTION 7, TOWNSHIP 6 NORTH, RANGE 2 EAST, SALT LAKE BASE AND MERIDIAN, U.S. SURVEY, MORE PARTICULARLY DESCRIBED AS FOLLOWS. BEGINNING AT A POINT BEING LOCATED NORTH 0°27'07" EAST 1198.23 FEET ALONG THE EAST LINE OF SAID SECTION AND NORTH 90°00'00" WEST 147.33 FEET; RUNNING THENCE SOUTH 1°49'06" EAST 532.39 FEET; THENCE NORTH 86°24'32" WEST 286.44 FEET; THENCE NORTH 1°28'53" WEST 209.78 FEET; THENCE NORTH 86°41'53" WEST 418.15 FEET; THENCE NORTH 1°28'53" WEST 262.42 FEET; THENCE NORTH 88°31'07" EAST 698.89 FEET TO THE POINT OF BEGINNING, CONTAINING 6.06 ACRES MORE OR LESS.

PARCEL "B" BOUNDARY DESCRIPTION

PART OF THE SOUTHEAST QUARTER OF SECTION 7, TOWNSHIP 6 NORTH, RANGE 2 EAST, SALT LAKE BASE AND MERIDIAN, U.S. SURVEY, MORE PARTICULARLY DESCRIBED AS FOLLOWS. BEGINNING AT A POINT BEING LOCATED NORTH 0°27'07" EAST 1198.23 FEET ALONG THE EAST LINE OF SAID SECTION AND NORTH 90°00'00" WEST 147.33 FEET; RUNNING THENCE SOUTH 88°31'07" WEST 698.89 FEET; THENCE NORTH 1°28'53" WEST 799.37 FEET; THENCE SOUTH 86°41'53" EAST 696.96 FEET; THENCE SOUTH 1°49'06" EAST 741.28 FEET TO THE POINT OF BEGINNING, CONTAINING 12.32 ACRES MORE OR LESS.

RECEIVED
SEP 17 2021
FILE # 6986

LEGEND

- WEBER COUNTY MONUMENT AS NOTED
- SET 24" REBAR AND CAP MARKED GARDNER ENGINEERING
- SUBJECT PROPERTY BOUNDARY
- LOT LINE
- ADJACENT PARCEL
- SECTION LINE
- EASEMENT
- EXISTING FENCE LINE

NARRATIVE

THE PURPOSE OF THIS SURVEY WAS TO ESTABLISH AND SET THE PROPERTY CORNERS OF THE PARCEL AS SHOWN AND DESCRIBED HEREON. THE SURVEY WAS ORDERED BY MARIE HIGGINS. THE BASIS OF BEARING IS THE EAST LINE OF SECTION 7, WHICH BEARS NORTH 0°27'07" EAST, WEBER COUNTY, UTAH NORTH, NAD 83 STATE PLANE GRID BEARING. THE BOUNDARY WAS DETERMINED BY WARRANTY DEED RECORDED AS ENTRY NUMBER 1315876 AND 2967212, AND DEEDS OF ADJOINING PROPERTY OWNERS. RECORD OF SURVEY NUMBER 9960 WAS ALSO USED TO DETERMINE THE BOUNDARY LOCATION ALONG WITH THE FOUND MONUMENTS AS SHOWN AND DESCRIBED HEREON.

SURVEYOR'S CERTIFICATE

I, KLINT H. WHITNEY, DO HEREBY CERTIFY THAT I AM A LICENSED PROFESSIONAL LAND SURVEYOR IN THE STATE OF UTAH AND THAT I HOLD CERTIFICATE NO. 8227228 IN ACCORDANCE WITH TITLE 58, CHAPTER 22, OF THE PROFESSIONAL ENGINEERS AND LAND SURVEYORS ACT. I FURTHER CERTIFY THAT BY AUTHORITY OF THE OWNERS I HAVE COMPLETED A SURVEY OF THE PROPERTY DESCRIBED ON THIS RECORD OF SURVEY PLAT IN ACCORDANCE WITH SECTION 17-23-20 AND HAVE VERIFIED ALL MEASUREMENTS; THAT THE REFERENCE MONUMENTS SHOWN ON THIS RECORD OF SURVEY PLAT ARE LOCATED AS INDICATED AND ARE SUFFICIENT TO RETRACE OR REESTABLISH THIS SURVEY; AND THAT THE INFORMATION SHOWN HEREIN IS SUFFICIENT TO ACCURATELY ESTABLISH THE LATERAL BOUNDARIES OF THE HEREIN DESCRIBED TRACT OF REAL PROPERTY.

SIGNED THIS 13TH DAY OF SEPTEMBER, 2021.

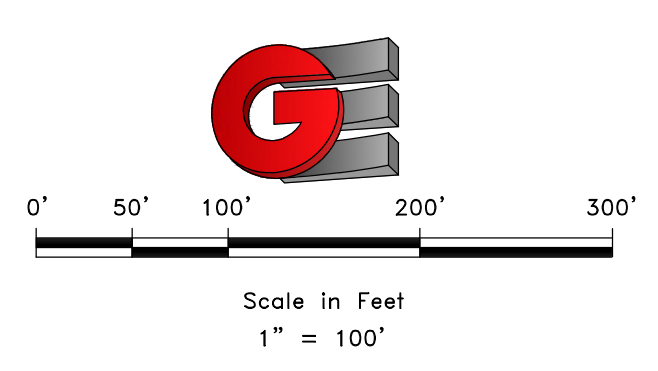

PROFESSIONAL LAND SURVEYOR
9/13/21
8227228
Klint H. Whitney
STATE OF UTAH

SCALE:	1:100 XREF:
DATE:	7/1/20
DESIGN:	
DRAWN:	KHW
CHECKED:	KHW
DWG.: 162001 - MISC SURVEY 1617 - MARIE HIGGINS SURVEY (CONV) MARIE HIGGINS DWG.	

REVISIONS	DESCRIPTION
DATE	

PROPERTY SURVEY FOR MARIE HIGGINS
304 N 7800 E, HUNTSVILLE UTAH
LOCATED IN THE SOUTHEAST QUARTER OF SECTION 7,
TOWNSHIP 6 NORTH, RANGE 2 EAST, S.L.B. AND M.

GARDNER ENGINEERING
CIVIL-LAND PLANNING
MUNICIPAL-LAND SURVEYING

5150 SOUTH 375 EAST OGDEN, UT
OFFICE: 801.476.0202 FAX: 801.476.0066

S1
1