

Keith Rounkles As Surveyed Description

A PART OF THE SOUTHEAST QUARTER OF SECTION 18, TOWNSHIP 6 NORTH, RANGE 1 EAST OF THE SALT LAKE BASE AND MERIDIAN.

BEGINNING AT THE INTERSECTION OF THE SOUTH RIGHT-OF-WAY LINE OF OGDEN CANYON ROAD (STATE HIGHWAY U-39) AND THE EAST BOUNDARY LINE OF THE KEITH B. ROUNKLES PROPERTY, TAX ID. NO. 20-024-0020 LOCATED 610.93 FEET NORTH 00°10'20\"/>

RUNNING THENCE SOUTH 00°05'13\"/>

(C1)	(C2)
$\Delta = 13^{\circ}59'27''$	$\Delta = 9^{\circ}14'53''$
$R = 319.48'$	$R = 254.83'$
$L = 78.01'$	$L = 41.13'$
$LC = 77.82'$	$LC = 41.09'$
$N 62^{\circ}35'39'' E$	$N 48^{\circ}41'04'' E$

RECEIVED
NOV 03 2021
BY: 1048

Narrative

THE PURPOSE OF THIS SURVEY WAS TO ESTABLISH AND SET THE PROPERTY CORNERS OF THE PARCEL AND TO IDENTIFY THE ALIGNMENT OF THE OGDEN CITY PIPE LINE, (THE OLD UTAH RAPID TRANSIT RAIL ROAD) AND TO IDENTIFY WHAT PORTIONS OF SAID ALIGNMENT IS OWNED BY OGDEN CITY AND WHICH IS EASEMENT ONLY AS SHOWN AND DESCRIBED HEREON. THE SURVEY WAS ORDERED BY KEITH ROUNKLES. THE CONTROL USED TO ESTABLISH THE PROPERTY CORNERS WAS CURRENT OCCUPATION LINES AND FOUND REBAR IN THE AREA OF THE SUBJECT PROPERTY ALONG WITH THE SUNRISE ENGINEERING SURVEY OF THE OGDEN CITY PIPE LINE, ROS #606 AND THE LANDMARK ROS #4742. THE OCCUPATION LINES ALL FALL ABOUT 108' WEST OF THE CURRENT WEBER COUNTY SURVEY MONUMENTATION. ALSO USED FOR ESTABLISHING THE PROPERTY LINES WAS THE EXISTING WEBER COUNTY SURVEY MONUMENTATION SURROUNDING SECTION 18, T6N, R1E, SLB&M. THE BASIS OF BEARING IS THE SOUTH LINE OF THE SOUTHEAST QUARTER OF SAID SECTION WHICH BEARS NORTH 83°21'02\"/>

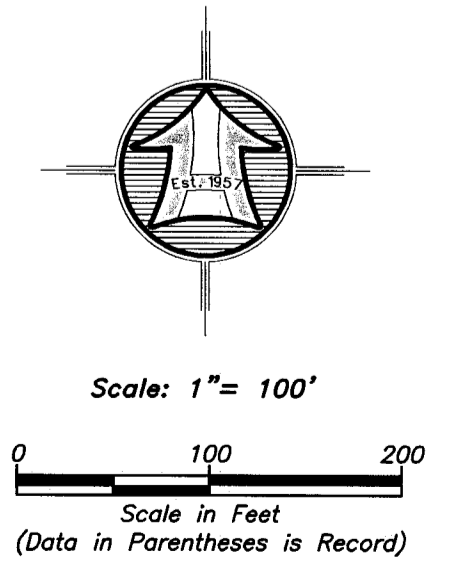

- LEGEND**
- Subject Property Line
 - - - - - Adjoining Property Line
 - - - - - Previous Property Line
 - Centerline
 - - - - - Ditch
 - - - - - Field Separation Line
 - - - - - Fence Line (Wire)
 - - - - - Fence Line (wood or Vinyl)
 - Street Monument
 - Found rebar set by others
 - Set 5/8"x24\"/>

SURVEYOR'S CERTIFICATE

I, K. Greg Hansen, do hereby certify that I am a Registered Professional Land Surveyor in the State of Utah in accordance with Title 58, Chapter 22, Professional Engineers and Professional Land Surveyors Act: and by the authority of the owners, I have completed a survey of the property described and shown hereon this plat in accordance with Section 17-23-17 and have verified all measurements, and that the same has been surveyed and monuments have been located and/or Placed on the ground as represented on the plat hereon.

Signed this 8th day of September, 2021.

K. Greg Hansen PLS
Utah Land Surveyor Licence No. 167819

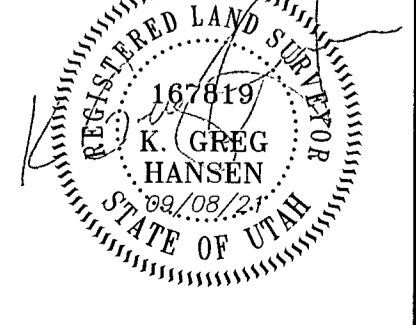

PROPERTY SURVEY FOR
Keith Rounkles
± 550 Ogdan Canyon Road
Ogdan Canyon, Weber County, Utah

A PART OF THE SOUTH HALF OF SECTION 18,
TOWNSHIP 6 NORTH, RANGE 1 EAST, S.L.B.&M.

Drawn By: KGH Date: 09/02/21
Checked By: RS
Approved By: KGH
Scale: 1" = 100'
Drawing File: 21-3-10_P8_V19
JOB NUMBER: 21-3-10

HANSEN & ASSOCIATES, INC.
Consulting Engineers and Land Surveyors
538 North Main Street, Brigham, Utah 84302
Visit us at www.hansen.net
Logan
Ogden
Brigham City
(435) 723-3481 (801) 399-4905 (435) 752-8272
Celebrating over 60 Years of Business

Sheet
1
of
1
Sheets