

BOUNDARY DESCRIPTION

PART OF THE SOUTHWEST QUARTER OF SECTION 32, TOWNSHIP 7 NORTH, RANGE 2 WEST, OF THE SALT LAKE BASE & MERIDIAN, BEGINNING AT A POINT LOCATED NORTH 00°00'00" EAST 299.93 FEET AND SOUTH 90°00'00" EAST 92.01 FEET AND NORTH 87°00'00" WEST 312.40 FEET FROM THE SOUTHEAST CORNER OF SAID SOUTHWEST QUARTER RUNNING THENCE SOUTH 19°11'54" WEST 263.59 FEET, THENCE NORTH 81°05'45" WEST 186.35 FEET, THENCE NORTH 01°03'38" WEST 549.77 FEET, THENCE NORTH 89°54'16" EAST 371.28 FEET, THENCE SOUTH 06°06'44" WEST 102.81 FEET, THENCE SOUTH 19°11'54" WEST 241.40 FEET TO THE POINT OF BEGINNING.

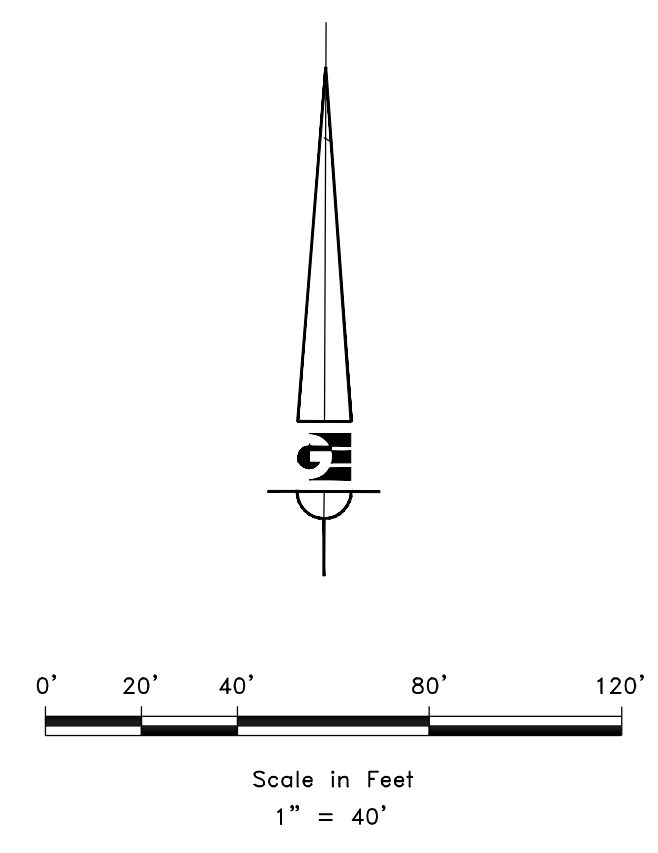

- LEGEND**
- ◆ WEBER COUNTY MONUMENT AS NOTED
 - SET 24" REBAR AND CAP MARKED GARDNER ENGINEERING
 - PROPERTY BOUNDARY
 - - - CENTERLINE
 - - - ADJACENT PARCEL
 - - - SECTION LINE

RECEIVED
MAR 25 2022
FILE # 7178

NARRATIVE

THE PURPOSE OF THIS SURVEY WAS TO ESTABLISH AND SET THE PROPERTY CORNERS OF THE PARCEL AS SHOWN AND DESCRIBED HEREON. THE SURVEY WAS ORDERED BY CARALEE KOTTER. THE BASIS OF BEARING IS THE SOUTH LINE OF THE NORTHWEST QUARTER OF SECTION 17, WHICH BEARS NORTH 1°02'48" EAST, WEBER COUNTY, UTAH NORTH, NAD 83 STATE PLANE GRID BEARING. THE BOUNDARY WAS DETERMINED BY WARRANTY DEED RECORDED AS ENTRY NUMBER 2877010, AND DEEDS OF ADJOINING PROPERTY OWNERS. RECORD OF SURVEY NUMBERS 4391, AND THE FOUND MONUMENTS AS SHOWN AND DESCRIBED HEREON.

SURVEYOR'S CERTIFICATE

I, KLINT H. WHITNEY, DO HEREBY CERTIFY THAT I AM A LICENSED PROFESSIONAL LAND SURVEYOR IN THE STATE OF UTAH AND THAT I HOLD CERTIFICATE NO. 8227228 IN ACCORDANCE WITH TITLE 58, CHAPTER 22, OF THE PROFESSIONAL ENGINEERS AND LAND SURVEYORS ACT. I FURTHER CERTIFY THAT BY AUTHORITY OF THE OWNERS I HAVE COMPLETED A SURVEY OF THE PROPERTY DESCRIBED ON THIS RECORD OF SURVEY PLAT IN ACCORDANCE WITH SECTION 17-23-20 AND HAVE VERIFIED ALL MEASUREMENTS; THAT THE REFERENCE MONUMENTS SHOWN ON THIS RECORD OF SURVEY PLAT ARE LOCATED AS INDICATED AND ARE SUFFICIENT TO RETRACE OR REESTABLISH THIS SURVEY; AND THAT THE INFORMATION SHOWN HEREIN IS SUFFICIENT TO ACCURATELY ESTABLISH THE LATERAL BOUNDARIES OF THE HEREIN DESCRIBED TRACT OF REAL PROPERTY.

SIGNED THIS 22ND DAY OF MARCH, 2022.

PROFESSIONAL LAND SURVEYOR
3/22/2022
8227228
Klint H. Whitney
KLINT H. WHITNEY, PLS NO. 8227228

| | |
|---|-----------|
| SCALE: | 1:40_XREF |
| DATE: | 8/31/18 |
| DESIGN: | |
| DRAWN: | MJL |
| CHECKED: | KHW |
| DWG.: R2001 - MISC SURVEY 0223 - CARALEE KOTTER SURVEY FOR CARALEE KOTTER.DWG | |

REVISIONS

| DATE | DESCRIPTION |
|------|-------------|
| | |
| | |

PROPERTY SURVEY FOR CARALEE KOTTER
PLAIN CITY, UTAH
LOCATED IN THE SOUTH HALF OF SECTION 32,
TOWNSHIP 7 NORTH, RANGE 2 WEST, S.L.B. AND M.

GARDNER ENGINEERING
CIVIL - LAND PLANNING
MUNICIPAL - LAND SURVEYING

5150 SOUTH 375 EAST OGDEN, UT
OFFICE: 801.476.0202 FAX: 801.476.0066

S1
1