

- LEGEND**
- Subject Property Line
 - - - Adjoining Property Line
 - Previous Property Line
 - Centerline
 - - - Ditch
 - - - Field Separation Line
 - - - Fence Line (Wire)
 - - - Fence Line (wood or Vinyl)
 - Street Monument
 - Found rebar set by others
 - Set 5/8"x24" Rebar With Cap
 - Section Corner

RECEIVED
MAY 13 2022
FILE # 7240

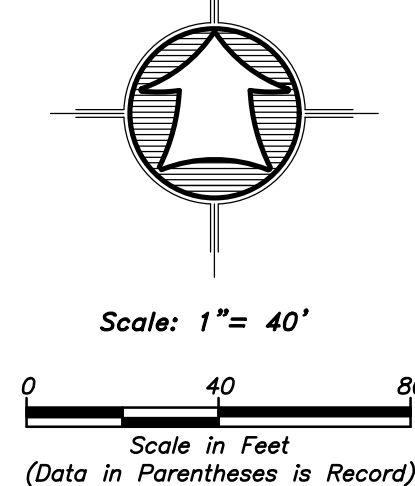

As Surveyed Boundary Description
A PART OF THE NORTHWEST QUARTER OF SECTION 33, TOWNSHIP 7 NORTH, RANGE 1 WEST OF THE SALT LAKE BASE AND MERIDIAN.

BEGINNING AT THE SOUTHEAST CORNER OF BLOCK 5, PLAT "A", NORTH OGDEN CITY SURVEY, SAID POINT BEING LOCATED 294.43 FEET SOUTH 00°45'11" WEST ALONG THE WEST LINE OF SAID NORTHWEST QUARTER AND 892.25 FEET SOUTH 89°03'07" EAST AND 409.31 FEET SOUTH 01°09'30" WEST FROM THE NORTHWEST CORNER OF SAID SECTION 33;

RUNNING THENCE NORTH 01°09'30" EAST 176.00 FEET ALONG THE WEST RIGHT-OF-WAY LINE OF 550 EAST STREET; THENCE NORTH 88°51'07" WEST 154.50 FEET; THENCE NORTH 01°09'30" EAST 37.00 FEET; THENCE NORTH 88°51'07" WEST 109.50 FEET TO THE EAST BOUNDARY LINE OF NORTH OGDEN CITY CENTER SUBDIVISION; THENCE SOUTH 01°09'30" WEST 213.00 FEET ALONG SAID EAST BOUNDARY LINE TO THE NORTH RIGHT-OF-WAY LINE OF 2550 NORTH STREET; THENCE SOUTH 88°51'07" EAST 264.00 FEET ALONG SAID NORTH RIGHT-OF-WAY LINE TO THE POINT OF BEGINNING. CONTAINING 50,516 SQUARE FEET OR 1.160 ACRES.

Narrative
The purpose of this survey was to establish and set the property corners of the parcels as shown and described hereon. The survey was ordered by Lorin Gardner for North Ogden City. The control used to establish the property corners was the existing street survey monumentation within the North Ogden City of Plat "A" and the Weber County Survey Monumentation surrounding Section 33, T. 7 N., R. 1 W., SLB&M. The basis of bearing is the west line of the northwest quarter of said section which bears South 00°45'11" West, Utah North, State Plane, Calculated N.A.D.83 Bearing.

SURVEYOR'S CERTIFICATE

I, K. Greg Hansen, do hereby certify that I am a Registered Professional Land Surveyor in the State of Utah in Accordance with Title 58, Chapter 22, Professional Engineers and Land Surveyors Act; and by the Authority of the Owners, I have Completed a Survey of the Property Described and shown Hereon this Plat in Accordance with Section 17-23-17 and have Verified all Measurements, and that the same has been Surveyed and Monuments have been Located and/or Placed on the Ground as Represented on the plat Hereon.

Signed this 29th day of October, 2021.

K. Greg Hansen PLS
Utah Land Surveyor Licence No. 167819

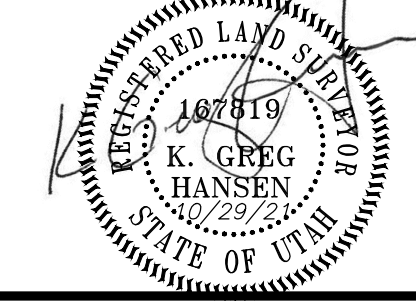

Property Survey for
North Ogden City
2557 North 550 East
North Ogden City, Weber County, Utah
A Part of the Northwest Quarter of Section 33,
Township 7 North, Range 1 West, S.L.B.&M.

Drawn By: kgh Date: 10/14/21
Designed By: rs
Checked By: rs
Approved By: K. Greg Hansen
Scale: 1" = 40'
Drawing File: 21-3-364 v19
JOB NUMBER: 21-3-364

HANSEN & ASSOCIATES, INC.
Consulting Engineers and Land Surveyors
536 North Main Street, Brigham, Utah 84302
Visit us at www.hansen.net
Logan
Ogden
Brigham City
(435) 725-3481 (801) 399-6605 (435) 752-8272

Sheet **1** of **1** Sheets