

NARRATIVE

THE PURPOSE OF THIS SURVEY WAS TO ESTABLISH AND SET THE PROPERTY CORNERS OF THE PARCEL AS SHOWN AND DESCRIBED HEREON. THE SURVEY WAS ORDERED BY JAMIE MONTANTES. THE CONTROL USED TO ESTABLISH THE PROPERTY CORNERS WAS THE OFFICIAL PLAT OF BILLINGS SUBDIVISION, RECORDED AS ENTRY NO. 1419249 ALONG WITH THE EXISTING WEBER COUNTY SURVEY MONUMENTATION SURROUNDING SECTION 6, T6N, R1W, SLB&M.

THE BASIS OF BEARING IS THE WEST LINE OF SAID SECTION WHICH BEARS SOUTH 0°42'15" EAST, AN ASSUMED BEARING, ROTATED TO MATCH THE BEARINGS SHOWN ON THE OFFICIAL PLAT OF SAID BILLINGS SUBDIVISION.

RECORD BOUNDARY DESCRIPTION

ALL OF LOT 1, BILLINGS SUBDIVISION, HARRISVILLE CITY, WEBER COUNTY, UTAH.

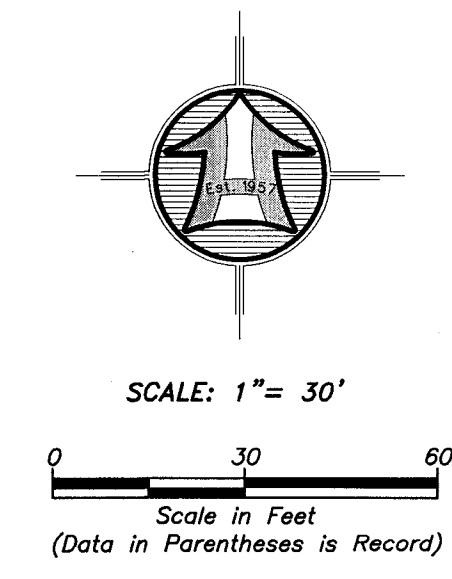

LEGEND

- SUBJECT PROPERTY LINE
- - - RIGHT-OF-WAY LINE
- - - SUBDIVISION BOUNDARY
- - - FENCE LINE
- - - CENTERLINE
- FOUND SURVEY MARKER SET BY OTHERS
- SET 5/8"X24" REBAR WITH CAP
- SECTION CORNER

RECEIVED
MAY 18 2022
BY: 7247

SURVEYOR'S CERTIFICATE

I, ROGER C. SLADE, DO HEREBY CERTIFY THAT I AM A REGISTERED PROFESSIONAL LAND SURVEYOR IN THE STATE OF UTAH IN ACCORDANCE WITH TITLE 58, CHAPTER 22, PROFESSIONAL ENGINEERS AND PROFESSIONAL LAND SURVEYORS ACT; AND BY THE AUTHORITY OF THE OWNERS, I HAVE COMPLETED A SURVEY OF THE PROPERTY DESCRIBED AND SHOWN HEREON THIS PLAT IN ACCORDANCE WITH SECTION 17-23-17 AND HAVE VERIFIED ALL MEASUREMENTS, AND THAT THE SAME HAS BEEN SURVEYED AND MONUMENTS HAVE BEEN LOCATED AND/OR PLACED ON THE GROUND AS REPRESENTED ON THE PLAT HEREON.

SIGNED THIS 29TH DAY OF MARCH, 2022.

ROGER C. SLADE, PLS
UTAH LAND SURVEYOR LICENCE NO. 11386802

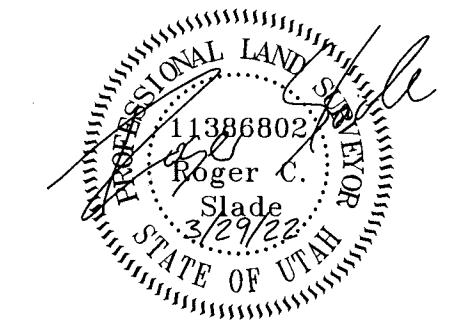

	<p>HANSEN & ASSOCIATES, INC. Consulting Engineers and Land Surveyors 538 North Main Street, Brigham, Utah 84302 Visit us at www.hansen.net Logan Brigham City (435) 723-3491 (801) 399-4905 (435) 752-8272 Celebrating over 60 Years of Business</p>
<p>Drawn By: RS Date: 03/29/2022</p> <p>Designed By: JMF</p> <p>Checked By: JMF</p> <p>Approved By: JMF</p> <p>Scale: 1" = 30'</p> <p>Drawing File: 22-5-51-18.dwg</p> <p>JOB NUMBER: 22-3-3-51</p>	<p>PROPERTY SURVEY FOR</p> <p>JAMIE MONTANTES</p> <p>619 WEST HARRISVILLE ROAD WEBER COUNTY, UTAH</p> <p>A PART OF THE SOUTHEAST QUARTER OF SECTION 6 TOWNSHIP 6 NORTH, RANGE 1 WEST, S.L.B.&M.</p>
<p>Sheet 1 of 1 Sheets</p>	