

**RECORD DESCRIPTION**  
 ALL OF LOT 24, GRAND LEGACY SUBDIVISION PHASE 2, PLEASANT VIEW CITY, WEBER COUNTY, UTAH.

**NARRATIVE**  
 THE PURPOSE OF THIS SURVEY WAS TO ESTABLISH AND SET THE PROPERTY CORNERS OF THE PARCEL AS SHOWN AND DESCRIBED HEREON. THE SURVEY WAS ORDERED BY LINDEE BESS FOR BEST REALTY. THE CONTROL USED TO ESTABLISH THE PROPERTY CORNERS WAS THE OFFICIAL PLAT OF GRAND LEGACY SUBDIVISION PHASE 2, RECORDED AS ENTRY NO. 1514532 ALONG WITH THE EXISTING WEBER COUNTY SURVEY MONUMENTATION SURROUNDING SECTION 20, T7N, R1W, SLB&M.  
 THERE IS A CONCRETE PAD THAT CROSSES THE PROPERTY LINE INTO LOT 25. A BOUNDARY LINE ADJUSTMENT IS RECOMMENDED TO FIX THE ISSUE.  
 THE BASIS OF BEARING IS BETWEEN TWO FOUND CENTERLINE MONUMENTS IN 4050 NORTH STREET WHICH BEARS NORTH 61°11'56\"/>

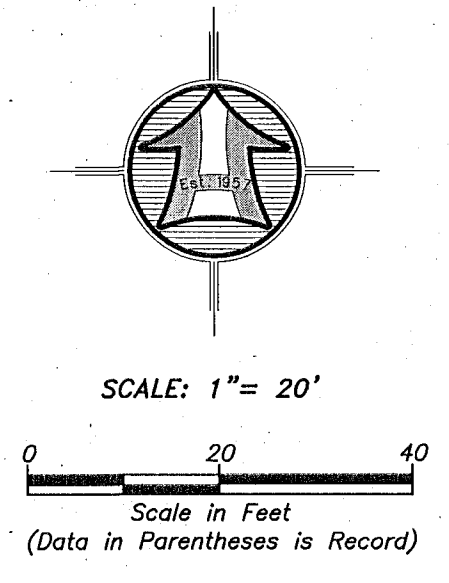

**LEGEND**

	SUBJECT PROPERTY LINE
	RIGHT-OF-WAY LINE
	ADJOINING DEED LINE
	ORIGINAL LOT LINE
	OCCUPATION LINE
	FENCE LINE
	CENTERLINE
	FOUND SURVEY MARKER SET BY OTHERS
	SET 5/8\"X24\" REBAR WITH CAP
	STREET MONUMENT
	SECTION CORNER

**RECEIVED**  
 JUL 14 2022  
 BY: 7291

**SURVEYOR'S CERTIFICATE**  
 I, MATT PRETL, DO HEREBY CERTIFY THAT I AM A REGISTERED PROFESSIONAL LAND SURVEYOR IN THE STATE OF UTAH IN ACCORDANCE WITH TITLE 58, CHAPTER 22, PROFESSIONAL ENGINEERS AND PROFESSIONAL LAND SURVEYORS ACT. AND BY THE AUTHORITY OF THE OWNERS, I HAVE COMPLETED A SURVEY OF THE PROPERTY DESCRIBED AND SHOWN HEREON THIS PLAT IN ACCORDANCE WITH SECTION 17-23-17 AND HAVE VERIFIED ALL MEASUREMENTS, AND THAT THE SAME HAS BEEN SURVEYED AND MONUMENTS HAVE BEEN LOCATED AND/OR PLACED ON THE GROUND AS REPRESENTED ON THE PLAT HEREON.  
 SIGNED THIS 28TH DAY OF JUNE, 2022.

MATT PRETL, PLS  
 UTAH LAND SURVEYOR LICENCE NO. 10437995

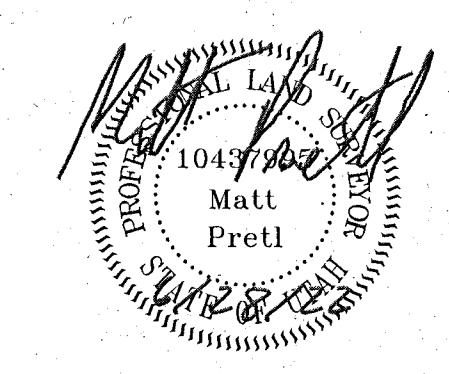

<p>PROPERTY SURVEY FOR  <b>LINDEE BESS</b>          152 W 4050 N          PLEASANT VIEW CITY, WEBER COUNTY, UTAH          A PART OF THE SOUTHEAST QUARTER OF SECTION 20,          TOWNSHIP 7 NORTH, RANGE 1 WEST, SLB&amp;M.</p>	
<p>Drawn By: MP          Checked By: RS          Approved By:          Scale: 1" = 20'          Drawing File: 22-3-92x19          JOB NUMBER: 22-3-92</p>	<p>Date: 5/13/2022</p>
<p>HANSEN &amp; ASSOCIATES, INC.          Consulting Engineers and Land Surveyors          538 North Main Street, Brigham, Utah 84302          Visit us at www.hansen.net          Brigham City, Utah          (435) 732-3491 (801) 399-4905 (435) 732-8272          Celebrating over 60 Years of Business</p>	
<p>Sheet  <b>1</b>          of  <b>1</b>          Sheets</p>	<p>No. _____          Date _____          By _____</p>

20221223-92 Lindee with Bess Realty Drawings\22-3-92x19.dwg, 6/28/2022 7:07:32 AM, DWG to PDF.pc