

**BOUNDARY DESCRIPTION PARCEL 210210004**

PART OF THE NORTHEAST QUARTER OF SECTION 15, TOWNSHIP 6 NORTH, RANGE 2 EAST, SALT LAKE MERIDIAN, U.S. SURVEY, BEGINNING AT THE NORTHWEST CORNER OF SAID QUARTER SECTION, THENCE SOUTH 70.00 RODS, MORE OR LESS, TO THE COUNTY ROAD, THENCE EAST 32.00 RODS, MORE OR LESS, TO HEADGATE IN MOUNTAIN CANAL, THENCE NORTH 70.00 RODS, MORE OR LESS, TO SECTION LINE, THENCE WEST ALONG SAID SECTION LINE 32.00 RODS TO THE PLACE OF BEGINNING, EXCEPT THE 1.76 ACRES, MORE OR LESS, IN THE OGDEN VALLEY CANAL, LESS AND EXCEPTING THEREFROM: A PART OF THE NORTHEAST ONE QUARTER OF SECTION 15, TOWNSHIP 6 NORTH, RANGE 2 EAST, SALT LAKE MERIDIAN, U.S. SURVEY, BEGINNING AT A POINT ON THE WEST PROPERTY LINE OF THE DARALD E MICHAELSON PROPERTY, SAID POINT BEING SOUTH 864.60 FEET FROM THE NORTHWEST CORNER OF SAID ONE QUARTER SECTION AND RUNNING THENCE SOUTH ALONG SAID WEST LINE 290.40 FEET TO THE NORTH RIGHT OF WAY LINE OF STATE HIGHWAY 39, THENCE EAST ALONG SAID NORTH RIGHT OF WAY LINE 150.00 FEET, THENCE NORTH 290.40 FEET, THENCE WEST 150.00 FEET TO THE POINT OF BEGINNING.

**BOUNDARY DESCRIPTION 210210074**

PART OF THE NORTHEAST QUARTER OF SECTION 15, TOWNSHIP 6 NORTH, RANGE 2 EAST, SALT LAKE MERIDIAN, U.S. SURVEY, BEGINNING ON THE NORTH LINE OF SAID QUARTER SECTION 32.00 RODS EAST OF THE NORTHWEST CORNER OF SAID QUARTER SECTION, THENCE SOUTH 70.00 RODS, THENCE EAST 16.00 RODS, THENCE NORTH 70.00 RODS, THENCE WEST ALONG THE NORTH LINE OF SAID QUARTER SECTION 16.00 RODS TO THE PLACE OF BEGINNING, EXCEPTING 0.46 ACRES IN THE OGDEN VALLEY CANAL, SUBJECT TO A BOUNDARY AGREEMENT E# 2614677.

**BOUNDARY DESCRIPTION 210210062**

ALL OF BAKER SUBDIVISION, WEBER COUNTY, UTAH.

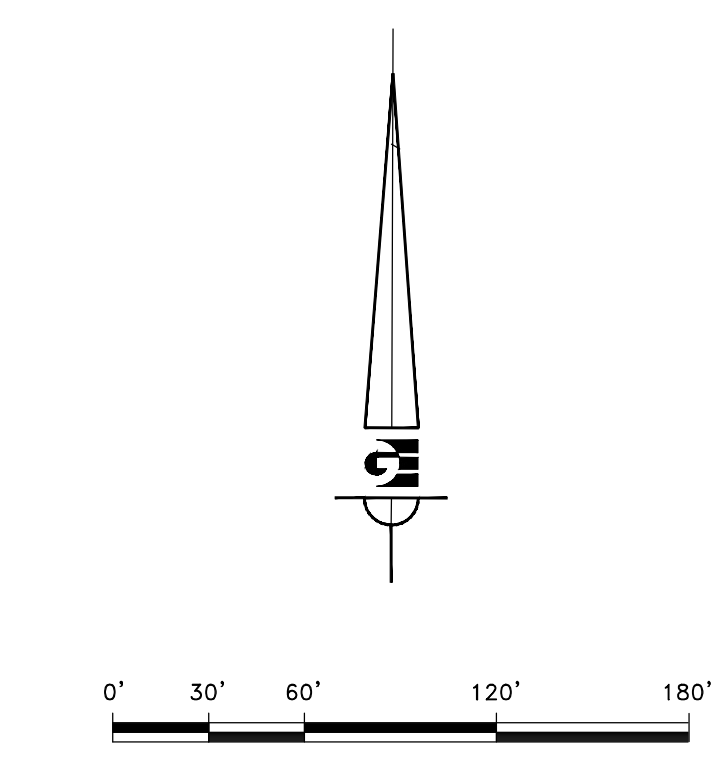

**LEGEND**

- WEBER COUNTY MONUMENT AS NOTED
- SET 24" REBAR AND CAP MARKED GARDNER ENGINEERING
- SUBJECT PROPERTY BOUNDARY
- LOT LINE
- ADJACENT PARCEL
- SECTION LINE
- EASEMENT
- EXISTING FENCE LINE

**NARRATIVE**

THE PURPOSE OF THIS SURVEY WAS TO ESTABLISH AND SET THE PROPERTY CORNERS OF THE PARCEL AS SHOWN AND DESCRIBED HEREON. THE SURVEY WAS ORDERED BY PAUL BAKER. THE BASIS OF BEARING IS THE NORTH LINE OF THE NORTHEAST QUARTER OF SECTION 15, WHICH BEARS NORTH 89°11'20" EAST, WEBER COUNTY, UTAH NORTH, NAD 83 STATE PLANE GRID BEARING. THE BOUNDARY WAS DETERMINED BY WARRANTY DEED RECORDED AS ENTRY NUMBER(S) 2491289, AND DEEDS OF ADJOINING PROPERTY OWNERS. RECORD OF SURVEY NUMBERS 3635, AND THE DEDICATED PLATS OF BAKER SUBDIVISION WERE ALSO USED TO DETERMINE BOUNDARY LOCATION ALONG WITH THE FOUND MONUMENTS AS SHOWN AND DESCRIBED HEREON.

**SURVEYOR'S CERTIFICATE**

I, KLINT H. WHITNEY, DO HEREBY CERTIFY THAT I AM A LICENSED PROFESSIONAL LAND SURVEYOR IN THE STATE OF UTAH AND THAT I HOLD CERTIFICATE NO. 8227228 IN ACCORDANCE WITH TITLE 58, CHAPTER 22, OF THE PROFESSIONAL ENGINEERS AND LAND SURVEYORS ACT; I FURTHER CERTIFY THAT BY AUTHORITY OF THE OWNERS I HAVE COMPLETED A SURVEY OF THE PROPERTY DESCRIBED ON THIS RECORD OF SURVEY PLAT IN ACCORDANCE WITH SECTION 17-23-20 AND HAVE VERIFIED ALL MEASUREMENTS; THAT THE REFERENCE MONUMENTS SHOWN ON THIS RECORD OF SURVEY PLAT ARE LOCATED AS INDICATED AND ARE SUFFICIENT TO RETRACE OR REESTABLISH THIS SURVEY; AND THAT THE INFORMATION SHOWN HEREIN IS SUFFICIENT TO ACCURATELY ESTABLISH THE LATERAL BOUNDARIES OF THE HEREIN DESCRIBED TRACT OF REAL PROPERTY.

SIGNED THIS 26TH DAY OF AUGUST, 2022.

PROFESSIONAL LAND SURVEYOR  
 8/26/2022  
 8227228  
 Klint H. Whitney  
 KLINT H. WHITNEY, PLS NO. 8227228

RECEIVED  
 AUG 29 2022  
 FILE # 7340

SCALE:	1" = 60'
DATE:	8/26/2022
DESIGN:	
DRAWN:	KHW
CHECKED:	KHW
DWG. NO.: R2001 - MISC SURVEY 02104 - PAUL BAKER SURVEY 02104/PAL BAKER DWG	

REVISIONS	DESCRIPTION
DATE	

PROPERTY SURVEY FOR PAUL BAKER  
 9922 EAST 200 SOUTH, HUNTSVILLE, UTAH  
 LOCATED IN THE NORTHEAST QUARTER OF SECTION 15,  
 TOWNSHIP 6 NORTH, RANGE 2 EAST, S.L.B. AND M.

**GARDNER ENGINEERING**  
 CIVIL-LAND PLANNING  
 MUNICIPAL-LAND SURVEYING  
 5150 SOUTH 375 EAST OGDEN, UT  
 OFFICE: 801.476.0202 FAX: 801.476.0066

**S1**  
**1**