

OSPREY RANCH SUBDIVISION PHASE 1
LOCATED IN THE SOUTHEAST QUARTER OF SECTION 33 TOWNSHIP 7 NORTH RANGE 1 EAST AND THE NORTH HALF OF SECTIONS 3, AND 4 OF TOWNSHIP 6 NORTH, RANGE 1 EAST, SALT LAKE BASE AND MERIDIAN, WEBER COUNTY, UTAH, OCTOBER 2022

PHASE 1 BOUNDARY DESCRIPTION

A PART OF THE SOUTHEAST QUARTER OF SECTION 33, TOWNSHIP 7 NORTH, RANGE 1 EAST AND A PART OF THE NORTH HALF OF SECTIONS 3 AND 4 OF TOWNSHIP 6 NORTH, RANGE 1 EAST, OF THE SALT LAKE BASE AND MERIDIAN. BEGINNING AT A POINT ON THE EAST LINE OF SAID SOUTHEAST QUARTER BEING LOCATED NORTH 00°22'52" EAST 1323.89 FEET ALONG THE EAST LINE OF SAID SECTION 33 FROM THE SOUTHEAST CORNER OF SAID SECTION 33; RUNNING THENCE ALONG SAID EAST LINE SOUTH 00°22'52" WEST 872.71 FEET; THENCE NORTH 70°00'53" WEST 107.12 FEET; THENCE SOUTH 10°11'47" WEST 178.55 FEET; THENCE SOUTH 05°08'51" EAST 152.07 FEET; THENCE SOUTH 00°17'39" WEST 390.00 FEET; THENCE SOUTH 89°19'35" EAST 1690.75 FEET TO THE WEST RIGHT-OF-WAY LINE OF STATE HIGHWAY 158. THENCE ALONG SAID WEST RIGHT-OF-WAY LINE THE FOLLOWING FOUR (4) COURSES: (1) SOUTH 28°32'40" EAST 650.08 FEET, (2) SOUTH 36°16'03" EAST 1586.42 FEET, (3) ALONG THE ARC OF A 1530.00 FOOT RADIUS CURVE TO THE RIGHT 383.09 FEET, HAVING A CENTRAL ANGLE OF 14°20'46", CHORD BEARS SOUTH 28°16'20" EAST 382.09 FEET, (4) SOUTH 19°05'57" EAST 476.77 FEET TO THE SOUTH LINE OF THE NORTHWEST QUARTER OF SAID SECTION 3; THENCE ALONG THE SOUTH LINE OF THE NORTHWEST QUARTER OF SAID SECTION 3 AND THE SOUTH LINE OF THE NORTHEAST QUARTER OF SAID SECTION 4 NORTH 90°00'00" WEST 4460.96 FEET; THENCE NORTH 00°15'53" EAST 1349.11 FEET; THENCE NORTH 45°00'00" EAST 160.42 FEET; THENCE NORTH 00°00'00" EAST 161.54 FEET; THENCE NORTH 53°49'45" EAST 44.12 FEET; THENCE ALONG THE ARC OF A 179.14 FOOT RADIUS CURVE TO THE RIGHT 47.39 FEET, HAVING A CENTRAL ANGLE OF 15°09'30", CHORD BEARS NORTH 21°33'54" WEST 47.26 FEET; THENCE NORTH 13°59'09" WEST 122.80 FEET; THENCE ALONG THE ARC OF A 122.00 FOOT RADIUS CURVE TO THE LEFT 118.61 FEET, HAVING A CENTRAL ANGLE OF 55°42'17", CHORD BEARS NORTH 41°50'18" WEST 114.00 FEET; THENCE NORTH 69°41'26" WEST 7.86 FEET; THENCE ALONG THE ARC OF A 328.00 FOOT RADIUS CURVE TO THE LEFT 16.92 FEET, HAVING A CENTRAL ANGLE OF 02°57'23", CHORD BEARS NORTH 71°10'07" WEST 16.92 FEET; THENCE NORTH 00°15'55" EAST 780.64 FEET ALONG THE EAST LINE OF LOT 2 OF SECTION 4 TOWNSHIP 6 NORTH, RANGE 1 EAST AND ITS PROJECTION; THENCE ALONG THE ARC OF A 120.68 FOOT RADIUS CURVE TO THE LEFT 53.53 FEET, HAVING A CENTRAL ANGLE OF 30°09'48", CHORD BEARS NORTH 78°44'38" WEST 62.80 FEET; THENCE ALONG THE ARC OF A 167.15 FOOT RADIUS CURVE TO THE RIGHT 101.44 FEET, HAVING A CENTRAL ANGLE OF 34°46'15", CHORD BEARS NORTH 73°52'07" WEST 99.89 FEET; THENCE NORTH 89°30'41" WEST 483.94 FEET; THENCE NORTH 00°11'58" EAST 1283.62 FEET; THENCE SOUTH 89°28'52" EAST 1965.83 FEET TO THE POINT OF BEGINNING. CONTAINING 283.83 ACRES.

AREA CALCULATIONS

TOTAL PROJECT AREA - 564.75 ACRES
PHASE 1 AREA - 283.84 ACRES
TOTAL COMMON AREA - 38.93 ACRES
PHASE 1 COMMON AREA - 28.54 ACRES

SURVEYOR'S CERTIFICATE

I, KLINT H. WHITNEY, DO HEREBY CERTIFY THAT I AM A LICENSED PROFESSIONAL LAND SURVEYOR IN THE STATE OF UTAH AND THAT I HOLD CERTIFICATE NO. 8227228 IN ACCORDANCE WITH TITLE 58, CHAPTER 22, OF THE PROFESSIONAL ENGINEERS AND LAND SURVEYORS ACT. I FURTHER CERTIFY THAT BY AUTHORITY OF THE OWNERS I HAVE COMPLETED A SURVEY OF THE PROPERTY AS SHOWN AND DESCRIBED ON THIS PLAT, AND HAVE SUBDIVIDED SAID PROPERTY INTO LOTS AND STREETS, TOGETHER WITH EASEMENTS, HEREAFTER TO BE KNOWN AS OSPREY RANCH PHASE 1 IN ACCORDANCE WITH SECTION 17-23-17 AND HAVE VERIFIED ALL MEASUREMENTS, THAT THE REFERENCE MONUMENTS SHOWN HEREON ARE LOCATED AS INDICATED AND ARE SUFFICIENT TO RETRACE OR REESTABLISH THIS SURVEY, THAT ALL LOTS MEET THE REQUIREMENTS OF THE LAND USE CODE, AND THAT THE INFORMATION SHOWN HEREIN IS SUFFICIENT TO SHOWCASE TO ACCURATELY ESTABLISH THE LATERAL BOUNDARIES OF THE HEREIN DESCRIBED TRACT OF REAL PROPERTY.

SIGNED THIS 24th DAY OF OCTOBER, 2022.

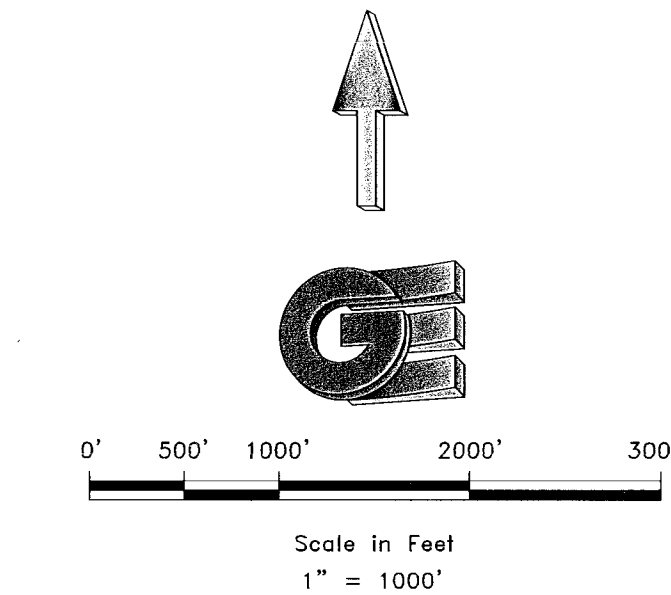
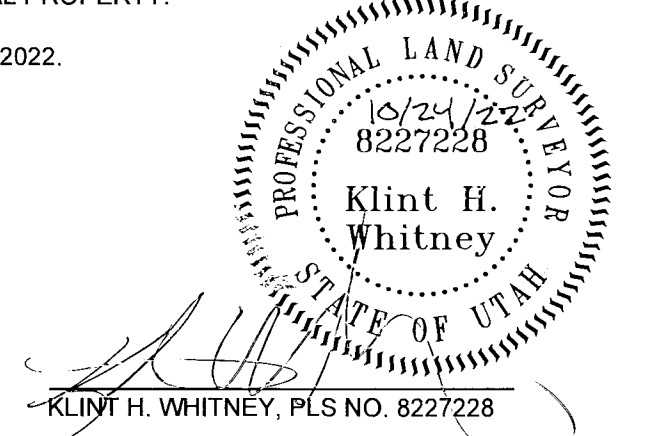

LEGEND

- WEBER COUNTY MONUMENT AS NOTED
SET 24" REBAR AND CAP MARKED GARDNER ENGINEERING
SUBDIVISION BOUNDARY
ADJACENT PARCEL
LOT LINE
SECTION LINE
EASEMENT
EXISTING FENCE LINE
DRAINAGE EASEMENT

OWNER'S DEDICATION

I THE UNDERSIGNED OWNER OF THE HEREON DESCRIBED TRACT OF LAND, HEREBY SET APART AND SUBDIVIDE THE SAME INTO LOTS, PARCELS AND STREETS AS SHOWN ON THIS PLAT AND NAME SAID TRACT:

OSPREY RANCH PHASE 1

AND HEREBY DEDICATE GRANT AND CONVEY TO WEBER COUNTY, UTAH ALL THOSE PARTS OR PORTIONS OF SAID TRACT OF LAND DESIGNATED AS STREETS, THE SAME TO BE USED AS PUBLIC THOROUGHFARES FOREVER, AND ALSO DOES HEREBY GRANT AND CONVEY TO THE OSPREY RANCH OWNERS ASSOCIATION, INC. (AND ITS SUCCESSORS AND ASSIGNS) WHOSE MEMBERSHIP CONSISTS OF THE MEMBERS/OWNERS OF SAID ASSOCIATION, THEIR GRANTEEES, SUCCESSORS AND/OR ASSIGNS ALL THOSE PART OR PORTIONS OF SAID TRACT OF LAND DESIGNATED AND DEPICTED ON SAID PLAT AS COMMON AREAS, WHICH ARE TO BE USED FOR PRIVATE RECREATIONAL AND OPEN SPACE PURPOSES BY AND FOR THE BENEFIT OF EACH ASSOCIATION MEMBER/OWNER IN COMMON WITH ALL OTHERS IN THE SUBDIVISION, WITH SUCH COMMON AREAS TO BE MAINTAINED BY SAID ASSOCIATION, AND DOES ALSO HEREBY GRANT AND CONVEY TO SAID ASSOCIATION ALL THOSE PARTS OR PORTIONS OF SAID TRACT OF LAND DESIGNATED AND DEPICTED ON SAID PLAT AS TRAILS AND TRAIL EASEMENTS, INCLUDING ANY SUCH TRAILS OR TRAIL EASEMENTS LOCATED ON ANY COMMON AREAS OR ON ANY INDIVIDUAL LOTS, WHICH TRAILS AND TRAIL EASEMENTS ARE TO BE USED FOR PRIVATE RECREATIONAL PURPOSES BY AND FOR THE BENEFIT OF THE ASSOCIATION'S MEMBERS/OWNERS AND IN COMMON WITH ALL OTHERS IN THE SUBDIVISION, WITH SUCH TRAILS AND TRAIL EASEMENTS TO BE MAINTAINED BY SAID ASSOCIATION, AND ALSO GRANT AND DEDICATE A PERPETUAL EASEMENT OVER, UPON AND UNDER THE LANDS DESIGNATED ON THE PLAT AS COMMON AREA, THE SAME TO BE USED FOR THE INSTALLATION, MAINTENANCE AND OPERATION OF PUBLIC UTILITY SERVICE LINES THAT SERVE LOTS WITHIN THE SUBDIVISION AND FOR STORM DRAINAGE FACILITIES OR THE PERPETUAL PRESERVATION OF WATER DRAINAGE CHANNELS IN THEIR NATURAL STATE, WHICHEVER IS APPLICABLE, AS MAY BE AUTHORIZED BY THE GOVERNING AUTHORITY, AND ALSO GRANTS AND DEDICATES TO WEBER COUNTY A PERPETUAL OPEN SPACE RIGHT AND EASEMENT ON AND OVER THE COMMON AREAS TO GUARANTEE TO WEBER COUNTY THAT SUCH COMMON AREAS REMAIN OPEN AND UNDEVELOPED EXCEPT FOR APPROVED RECREATIONAL, PARKING AND OPEN SPACE PURPOSES, AND ALSO GRANTS AND DEDICATES A PERPETUAL RIGHT AND EASEMENT OVER, UPON AND UNDER THE LANDS DESIGNATED ON THE PLAT AS PUBLIC UTILITY, STORM WATER DETENTION PONDS AND DRAINAGE EASEMENTS, TO BE USED FOR THE INSTALLATION, MAINTENANCE AND OPERATION OF PUBLIC UTILITY SERVICE LINES THAT SERVE LOTS WITHIN THE SUBDIVISION AND FOR STORM DRAINAGE FACILITIES OR THE PERPETUAL PRESERVATION OF WATER DRAINAGE CHANNELS IN THEIR NATURAL STATE, WHICHEVER IS APPLICABLE, AS MAY BE AUTHORIZED BY THE GOVERNING AUTHORITY, WITH NO BUILDINGS OR STRUCTURES BEING ERRECTED WITHIN SUCH EASEMENTS AND ALSO GRANT DEDICATE AND CONVEY LAND DESIGNATED AS SEWER EASEMENT TO WOLF CREEK WATER AND SEWER IMPROVEMENT DISTRICT FOR THE PURPOSE OF INSTALLING, MAINTAINING AND REPAIRING SANITARY SEWER LINES AND STRUCTURES AND ALSO GRANT DEDICATE AND CONVEY TO WEBER COUNTY LAND DESIGNATED AS DRAINAGE EASEMENT TO WEBER COUNTY FOR DRAINAGE AND STORM DRAINAGE PURPOSES.

Table with 5 columns: CURVE #, LENGTH, RADIUS, DELTA, CHORD BEARING, CHORD LENGTH. Contains data for curves C1 through C6.

NOTES

- ZONE FV-3 CURRENT YARD SETBACKS: FRONT 30', SIDE 20' - SIDE FACING STREET ON CORNER 30', REAR MAIN BUILDING 30' - ACCESSORY BUILDING 10'.
SUBJECT PROPERTY FALLS WITHIN FEMA FLOOD ZONE "X" - AREAS DETERMINED TO BE OUTSIDE THE 0.2% ANNUAL CHANCE FLOODPLAIN, PER FEMA MAP NO. 49057C0237F WITH AN EFFECTIVE DATE OF JUNE 2, 2015.
A NATURAL HAZARD NOTICE SHALL BE RECORDED WITH THE PLAT, AND A NOTE ON THE FINAL PLAT SHALL BE REQUIRED WHICH STATES THAT THE PARCEL IS LOCATED WITHIN A NATURAL HAZARD STUDY AREA.
A LOT WITH A DELINEATED "BUILDABLE AREA" SHALL ONLY ALLOW BUILDINGS WITHIN THE DESIGNATED BUILDABLE AREA.
EACH LOT SHALL BE RESPONSIBLE TO PROVIDE INDIVIDUAL LOT DETENTION. CALCULATIONS FOR DETAINING STORM WATER SHALL BE INCLUDED AS PART OF BUILDING PERMIT.

RECORDED OCT 25 2022 BY 7383

ACKNOWLEDGEMENT

STATE OF UTAH)
COUNTY OF WEBER)

On this day of 2022, personally appeared before me CARL LORENTZEN, whose identity is personally known to me (or proven on the basis of satisfactory evidence) and who by me duly sworn/affirmed, did say that he/she is the TRUSTEE OF THE CARL LORENTZEN LIVING TRUST, DATED SEPTEMBER 12, 2003, AMENDED AND RESTATED OCTOBER 20, 2016, and that said document was signed by him/her in behalf of said Trust by Authority of its Bylaws, or (Resolution of its Board of Directors), and said CARL LORENTZEN acknowledged to me that said Trust executed the same.

SIGNED THIS DAY OF 2022.

OSPREY RANCH, LLC

BY: JOHN LEWIS, MANAGING MEMBER

THE CARL LORENTZEN LIVING TRUST, DATED SEPTEMBER 12, 2003, AMENDED AND RESTATED OCTOBER 20, 2016

BY: CARL LORENTZEN, TRUSTEE

ACKNOWLEDGEMENT

STATE OF UTAH)
COUNTY OF WEBER)

On this day of 2022, personally appeared before me JOHN LEWIS, whose identity is personally known to me (or proven on the basis of satisfactory evidence) and who by me duly sworn/affirmed, did say that he/she is the MANAGING MEMBER OF OSPREY RANCH, LLC, and that said document was signed by him/her in behalf of said Corporation by Authority of its Bylaws, or (Resolution of its Board of Directors), and said JOHN LEWIS acknowledged to me that said Corporation executed the same.

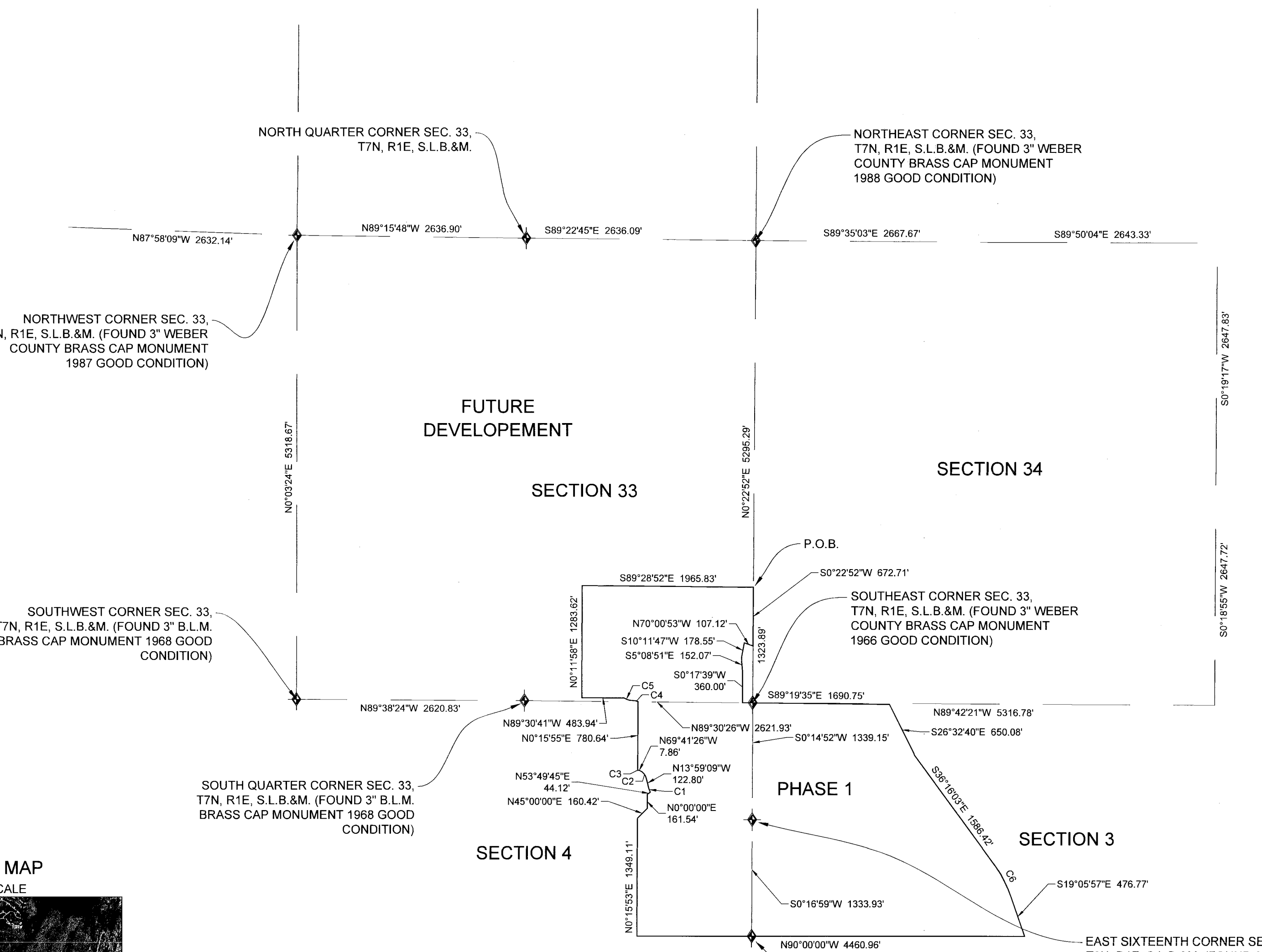

VICINITY MAP NOT TO SCALE

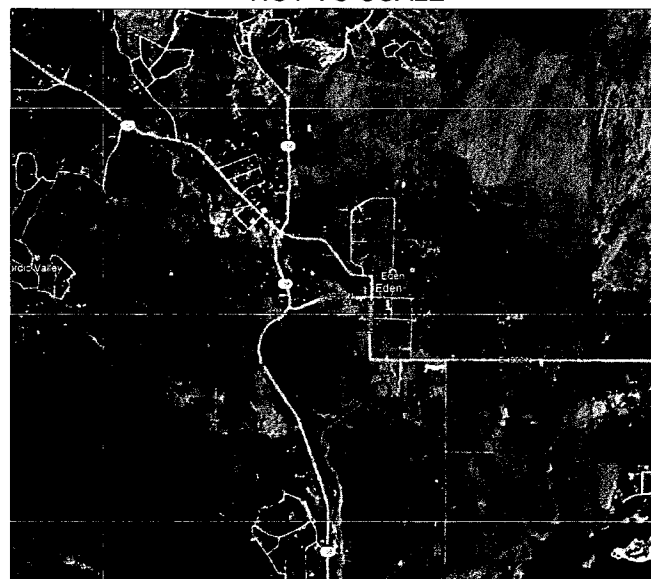

NORDIC MOUNTAIN WATER INC.

APPROVED BY NORDIC MOUNTAIN WATER INC. ON

THE DAY OF 20

PRESIDENT: BILL GREEN

WOLF CREEK WATER AND SEWER IMPROVEMENT DISTRICT

APPROVED BY WOLF CREEK WATER AND SEWER IMPROVEMENT DISTRICT ON

THE DAY OF 20

MANAGER: ROB THOMAS

WEBER COUNTY SURVEYOR

I HEREBY CERTIFY THAT THE WEBER COUNTY SURVEYOR'S OFFICE HAS REVIEWED THIS PLAT AND ALL CONDITIONS FOR APPROVAL BY THIS OFFICE HAVE BEEN SATISFIED. THE APPROVAL OF THIS PLAT BY THE WEBER COUNTY SURVEYOR DOES NOT RELIEVE THE LICENSED LAND SURVEYOR WHO EXECUTED THIS PLAT FROM THE RESPONSIBILITIES AND/OR LIABILITIES ASSOCIATED THEREWITH.

SIGNED THIS DAY OF 2022.

COUNTY SURVEYOR

RECORD OF SURVEY:

WEBER COUNTY ATTORNEY

I HAVE EXAMINED THE FINANCIAL GUARANTEE AND OTHER DOCUMENTS ASSOCIATED WITH THIS SUBDIVISION PLAT AND IN MY OPINION THEY CONFORM WITH THE COUNTY ORDINANCE APPLICABLE THERETO AND NOW IN FORCE AND EFFECT.

SIGNED THIS DAY OF 2022.

COUNTY ATTORNEY

WEBER COUNTY ENGINEER

I HEREBY CERTIFY THAT THE REQUIRED PUBLIC IMPROVEMENT STANDARDS AND DRAWINGS FOR THIS SUBDIVISION CONFORM WITH COUNTY STANDARDS AND THE AMOUNT OF THE FINANCIAL GUARANTEE IS SUFFICIENT FOR THE INSTALLATION OF THESE IMPROVEMENTS.

SIGNED THIS DAY OF 2022.

COUNTY ENGINEER

WEBER COUNTY COMMISSION ACCEPTANCE

THIS IS TO CERTIFY THAT THIS SUBDIVISION PLAT, THE DEDICATION OF STREETS AND OTHER PUBLIC WAYS AND FINANCIAL GUARANTEE OF PUBLIC IMPROVEMENTS ASSOCIATED WITH THIS SUBDIVISION THEREON ARE HEREBY APPROVED AND ACCEPTED BY THE COMMISSIONERS OF WEBER COUNTY, UTAH.

SIGNED THIS DAY OF 2022.

CHAIRMAN, WEBER COUNTY COMMISSION

ATTEST: NAME/TITLE

WEBER COUNTY PLANNING COMMISSION APPROVAL

THIS IS TO CERTIFY THAT THIS SUBDIVISION WAS DULY APPROVED BY THE WEBER COUNTY PLANNING COMMISSION.

SIGNED THIS DAY OF 2022.

CHAIRMAN, WEBER COUNTY PLANNING COMMISSION

STAMP

NOTARY PUBLIC

NARRATIVE

THE PURPOSE OF THIS SURVEY WAS TO CREATE A SUBDIVISION ON THE PROPERTY AS SHOWN AND DESCRIBED HEREON. THE SURVEY WAS ORDERED BY OSPREY RANCH LLC. THE CONTROL USED TO ESTABLISH THE BOUNDARY WAS THE EXISTING WEBER COUNTY SURVEY MONUMENTATION AS SHOWN AND NOTED HEREON. THE BASIS OF BEARING IS THE EAST LINE OF SECTION 33, TOWNSHIP 7 NORTH, RANGE 1 EAST, OF THE SALT LAKE BASE AND MERIDIAN WHICH BEARS NORTH 00°22'52" EAST WEBER COUNTY, UTAH NORTH, NAD 83 STATE PLANE GRID BEARING. THE RIGHT-OF-WAY OF HIGHWAY 158 WAS ESTABLISHED BY DRAWINGS RECEIVED FROM U.D.O.T. REGION 1 FEDERAL AID PROJECT H99-0158(116)0 PIN-5522 DATED 4/30/2012. WARRANTY DEEDS RECORDED AS ENTRY NUMBERS 3143804, 3145237, 3145286 AND DEEDS OF ADJOINING PROPERTY OWNERS, RECORD OF SURVEY NUMBERS 1002, 293, 4608, 5102, 3584, AND THE DEDICATED PLATS OF BIG SKY ESTATES NO. 1, BIG SKY ESTATES NO. 2, BLAKE HOLLEY SUBDIVISION, EDEN ESTATES SUBDIVISION WERE ALSO USED TO DETERMINE BOUNDARY LOCATION.

STAMP

NOTARY PUBLIC

DEVELOPER: OSPREY RANCH LLC
JOHN LEWIS
3718 NORTH WOLF CREEK DRIVE
EDEN, UTAH, 84310
801-430-1507

S1 7

COUNTY RECORDER

ENTRY NO. FEE PAID
FILED FOR AND RECORDED
AT IN BOOK OF OFFICIAL
RECORDS, PAGE RECORDED
FOR
COUNTY RECORDER
BY:



PLAT NO. 1 - LEWIS HOMES 2105 - OSPREY RANCH SURVEYING AND ENGINEERING - OSPREY RANCH PHASE 1 PLAT REVISED LOTS BLOCKING

OSPREY RANCH SUBDIVISION PHASE 1

LOCATED IN THE SOUTHEAST QUARTER OF SECTION 33 TOWNSHIP 7 NORTH RANGE 1 EAST AND THE NORTH HALF OF SECTIONS 3, AND 4 OF TOWNSHIP 6 NORTH, RANGE 1 EAST, SALT LAKE BASE AND MERIDIAN, WEBER COUNTY, UTAH, OCTOBER 2022

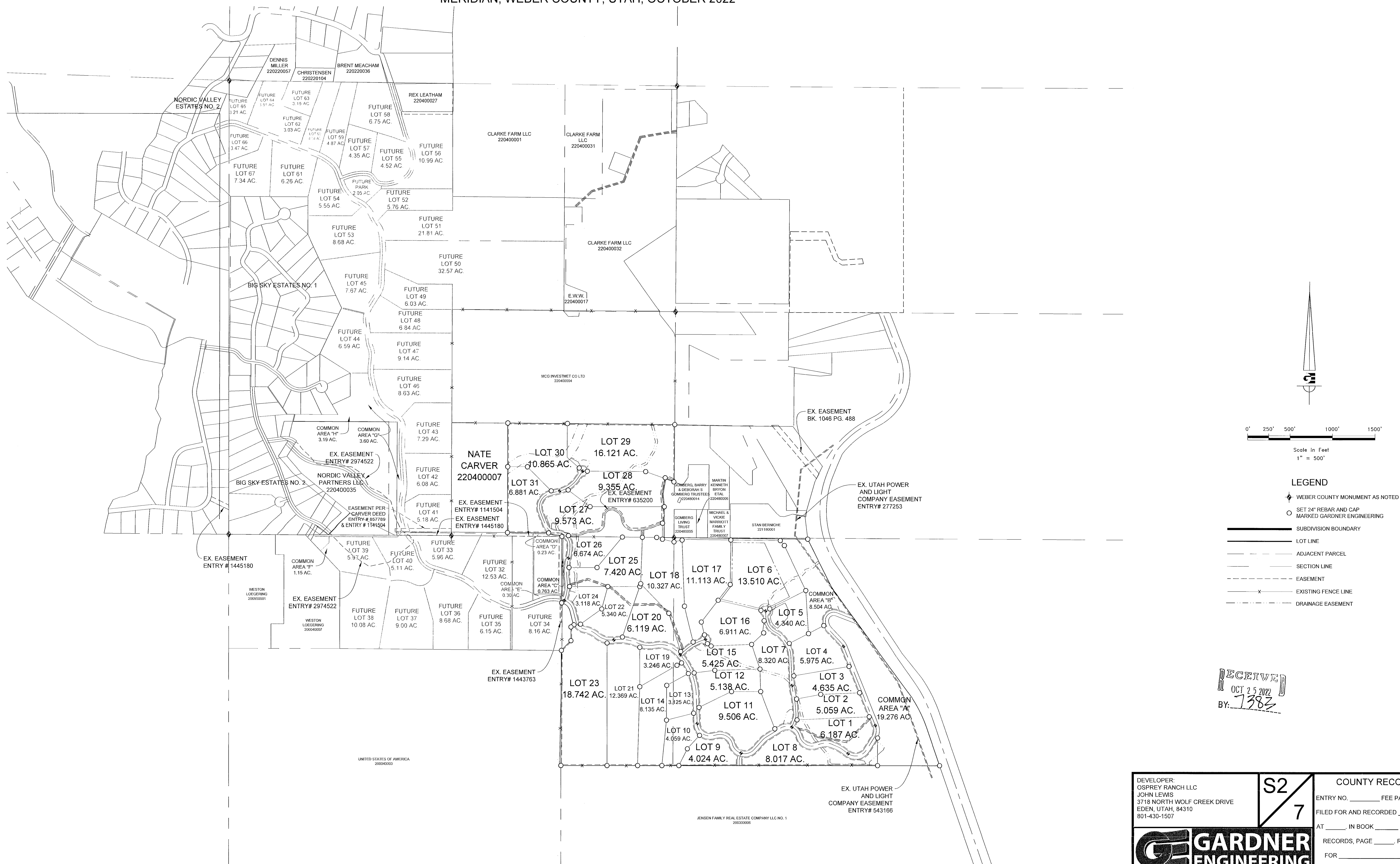

RECEIVED
OCT 25 2022
BY: [Signature]

DEVELOPER: OSPREY RANCH LLC JOHN LEWIS 3718 NORTH WOLF CREEK DRIVE EDEN, UTAH, 84310 801-430-1507	S2	7	COUNTY RECORDER
	ENTRY NO. _____ FEE PAID _____ FILED FOR AND RECORDED _____ AT _____ IN BOOK _____ OF OFFICIAL RECORDS, PAGE _____ RECORDED FOR _____ COUNTY RECORDER BY: _____		
GARDNER ENGINEERING CIVIL • LAND PLANNING MUNICIPAL • LAND SURVEYING 5150 SOUTH 375 EAST OGDEN, UT OFFICE: 801.476.0202 FAX: 801.476.0066			

R:\1201 - LEWIS HOMES\2105 - OSPREY RANCH\SURVEY\DWG\OSPREY RANCH PHASE 1 PLAT REVISED LOTS BLOCK.DWG

OSPREY RANCH SUBDIVISION PHASE 1

LOCATED IN THE SOUTHEAST QUARTER OF SECTION 33 TOWNSHIP 7 NORTH RANGE 1 EAST AND THE NORTH HALF OF SECTIONS 3, AND 4 OF TOWNSHIP 6 NORTH, RANGE 1 EAST, SALT LAKE BASE AND MERIDIAN, WEBER COUNTY, UTAH, OCTOBER 2022

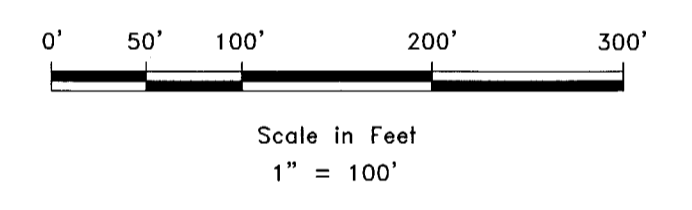
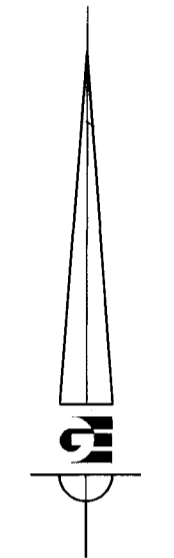
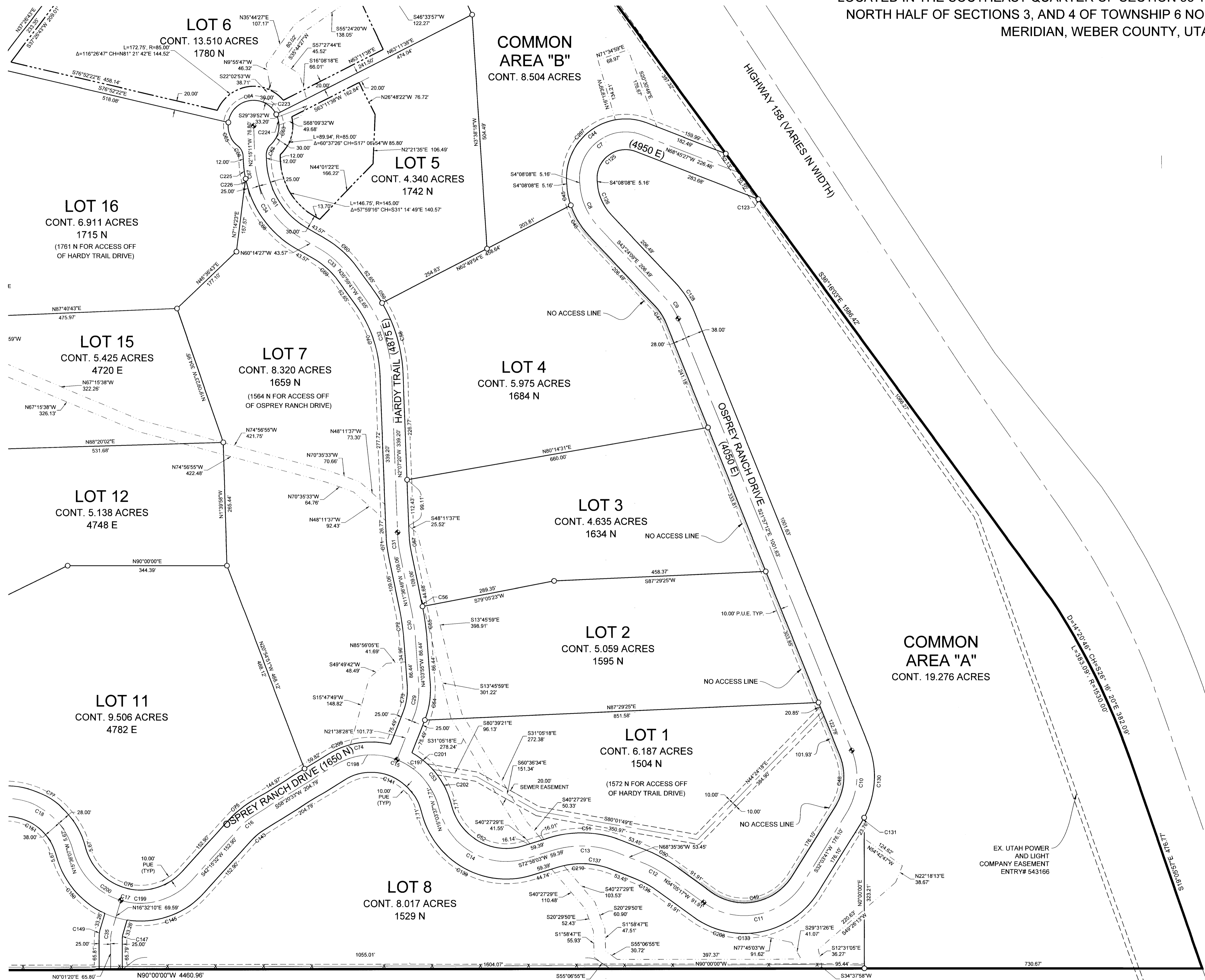

LEGEND

- ◆ WEBER COUNTY MONUMENT AS NOTED
- SET 24" REBAR AND CAP MARKED GARDNER ENGINEERING
- SUBDIVISION BOUNDARY
- LOT LINE
- - - ADJACENT PARCEL
- - - SECTION LINE
- - - EASEMENT
- - - EXISTING FENCE LINE
- - - BUILDABLE AREA SEE NOTE 4
- - - DRAINAGE EASEMENT
- ||||| NO ACCESS LINE

RECEIVED
OCT 25 2022
BY: 1383

DEVELOPER:
OSPREY RANCH LLC
JOHN LEWIS
3718 NORTH WOLF CREEK DRIVE
EDEN, UTAH, 84310
801-430-1507

GARDNER ENGINEERING
CIVIL • LAND PLANNING
MUNICIPAL • LAND SURVEYING
5150 SOUTH 375 EAST OGDEN, UT
OFFICE: 801.476.0202 FAX: 801.476.0066

S3
7

COUNTY RECORDER

ENTRY NO. _____ FEE PAID _____

FILED FOR AND RECORDED _____

AT _____ IN BOOK _____ OF OFFICIAL _____

RECORDS, PAGE _____, RECORDED _____

FOR _____

COUNTY RECORDER _____

BY: _____

R1201 - LEWIS HOMES2105 - OSPREY RANCH SURVEY DRAWING OSPREY RANCH PHASE 1 PLAT REVISED LOTS BLOCK.DWG

OSPREY RANCH SUBDIVISION PHASE 1

LOCATED IN THE SOUTHEAST QUARTER OF SECTION 33 TOWNSHIP 7 NORTH RANGE 1 EAST AND THE NORTH HALF OF SECTIONS 3, AND 4 OF TOWNSHIP 6 NORTH, RANGE 1 EAST, SALT LAKE BASE AND MERIDIAN, WEBER COUNTY, UTAH, OCTOBER 2022

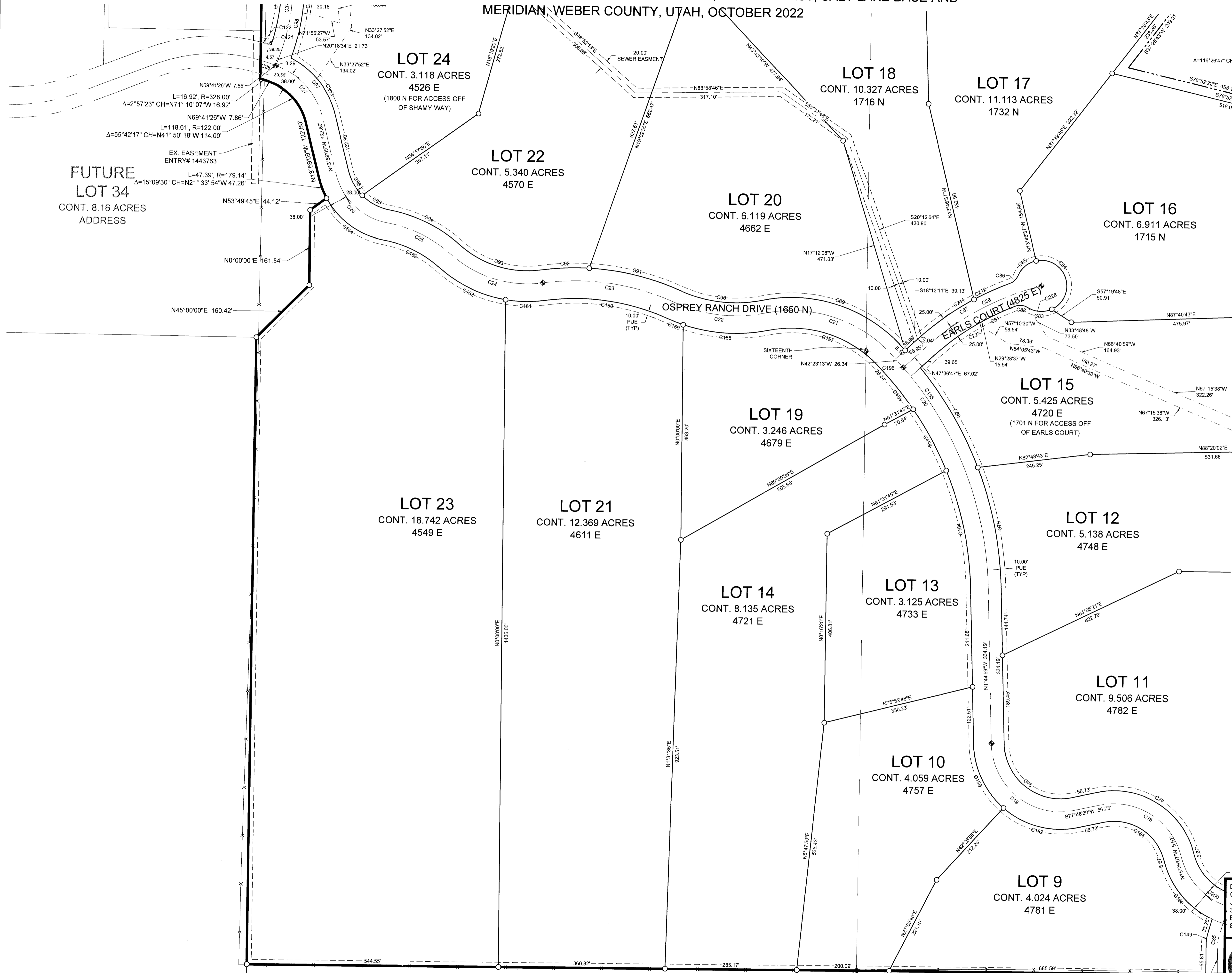

FUTURE LOT 34
CONT. 8.16 ACRES
ADDRESS

LOT 24
CONT. 3.118 ACRES
4526 E
(1800 N FOR ACCESS OFF OF SHAMY WAY)

LOT 22
CONT. 5.340 ACRES
4570 E

LOT 20
CONT. 6.119 ACRES
4662 E

LOT 18
CONT. 10.327 ACRES
1716 N

LOT 17
CONT. 11.113 ACRES
1732 N

LOT 16
CONT. 6.911 ACRES
1715 N

OSPREY RANCH DRIVE (1650 N)

EARLS COURT (4825 E)*

LOT 19
CONT. 3.246 ACRES
4679 E

LOT 15
CONT. 5.425 ACRES
4720 E
(1701 N FOR ACCESS OFF OF EARLS COURT)

LOT 23
CONT. 18.742 ACRES
4549 E

LOT 21
CONT. 12.369 ACRES
4611 E

LOT 12
CONT. 5.138 ACRES
4748 E

LOT 14
CONT. 8.135 ACRES
4721 E

LOT 13
CONT. 3.125 ACRES
4733 E

LOT 11
CONT. 9.506 ACRES
4782 E

LOT 10
CONT. 4.059 ACRES
4757 E

LOT 9
CONT. 4.024 ACRES
4781 E

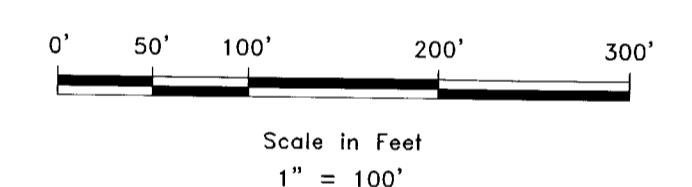
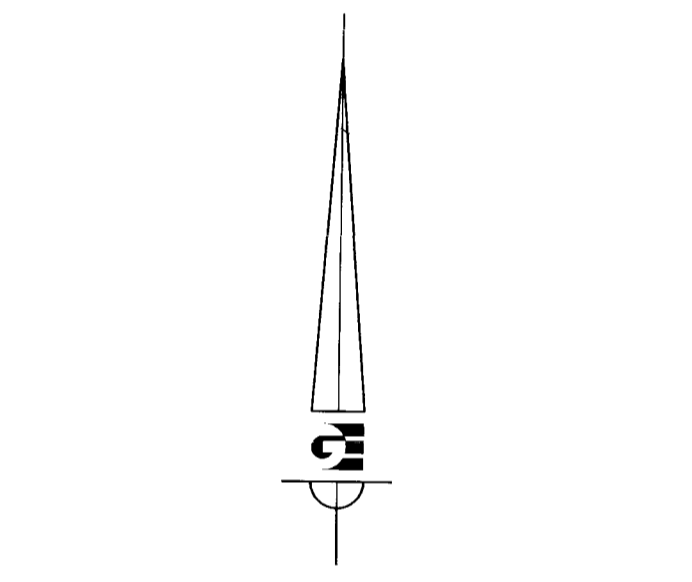

- LEGEND**
- ◆ WEBER COUNTY MONUMENT AS NOTED
 - SET 24" REBAR AND CAP MARKED GARDNER ENGINEERING
 - SUBDIVISION BOUNDARY
 - LOT LINE
 - - - ADJACENT PARCEL
 - - - SECTION LINE
 - - - EASEMENT
 - - - EXISTING FENCE LINE
 - - - BUILDABLE AREA SEE NOTE 4
 - - - DRAINAGE EASEMENT

RECEIVED
OCT 25 2022
BY: 1383

EAST QUARTER CORNER SEC. 4, T6N, R1E, S1/4 S.M. (FOUND 3" WEBER COUNTY BRASS CAP MONUMENT 1967 GOOD CONDITION)

DEVELOPER:
OSPREY RANCH LLC
JOHN LEWIS
3718 NORTH WOLF CREEK DRIVE
EDEN, UTAH, 84310
801-430-1507

S4
7

COUNTY RECORDER
ENTRY NO. _____ FEE PAID _____
FILED FOR AND RECORDED _____
AT _____ IN BOOK _____ OF OFFICIAL _____
RECORDS, PAGE _____, RECORDED _____
FOR _____
WEBER COUNTY RECORDER
BY: _____

GARDNER ENGINEERING
CIVIL ENGINEERING
MUNICIPAL ENGINEERING
5150 SOUTH 375 EAST OGDEN, UT
OFFICE: 801.476.0202 FAX: 801.476.0066

R:\1201 - LEWIS HOMES\2105 - OSPREY RANCH\SUBDIVISION\OSPREY RANCH PHASE 1 PLAT REVISED LOTS BLOCK.DWG

OSPREY RANCH SUBDIVISION PHASE 1
 LOCATED IN THE SOUTHEAST QUARTER OF SECTION 33 TOWNSHIP 7 NORTH RANGE 1 EAST AND THE
 NORTH HALF OF SECTIONS 3, AND 4 OF TOWNSHIP 6 NORTH, RANGE 1 EAST, SALT LAKE BASE AND
 MERIDIAN, WEBER COUNTY, UTAH, OCTOBER 2022

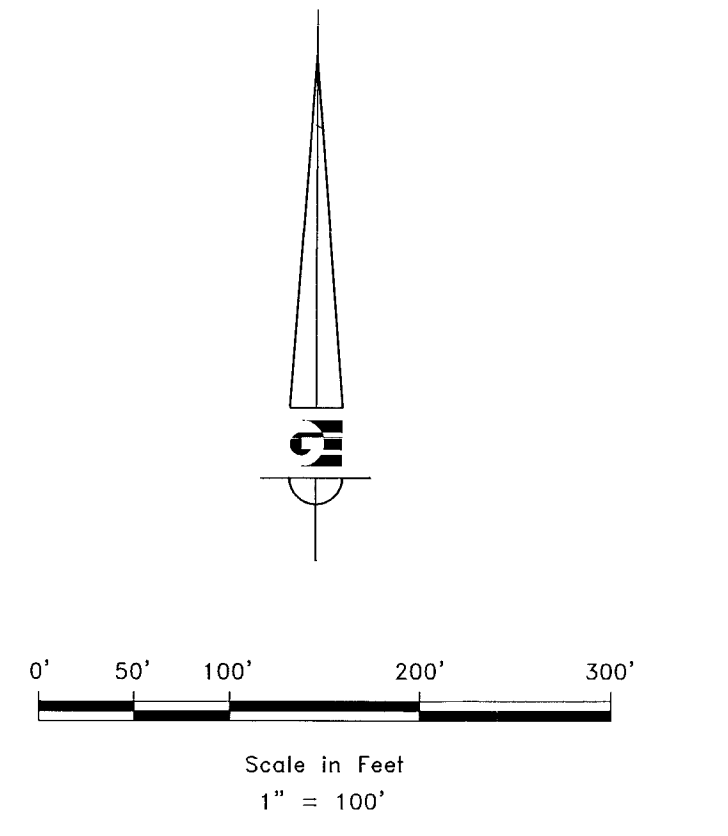
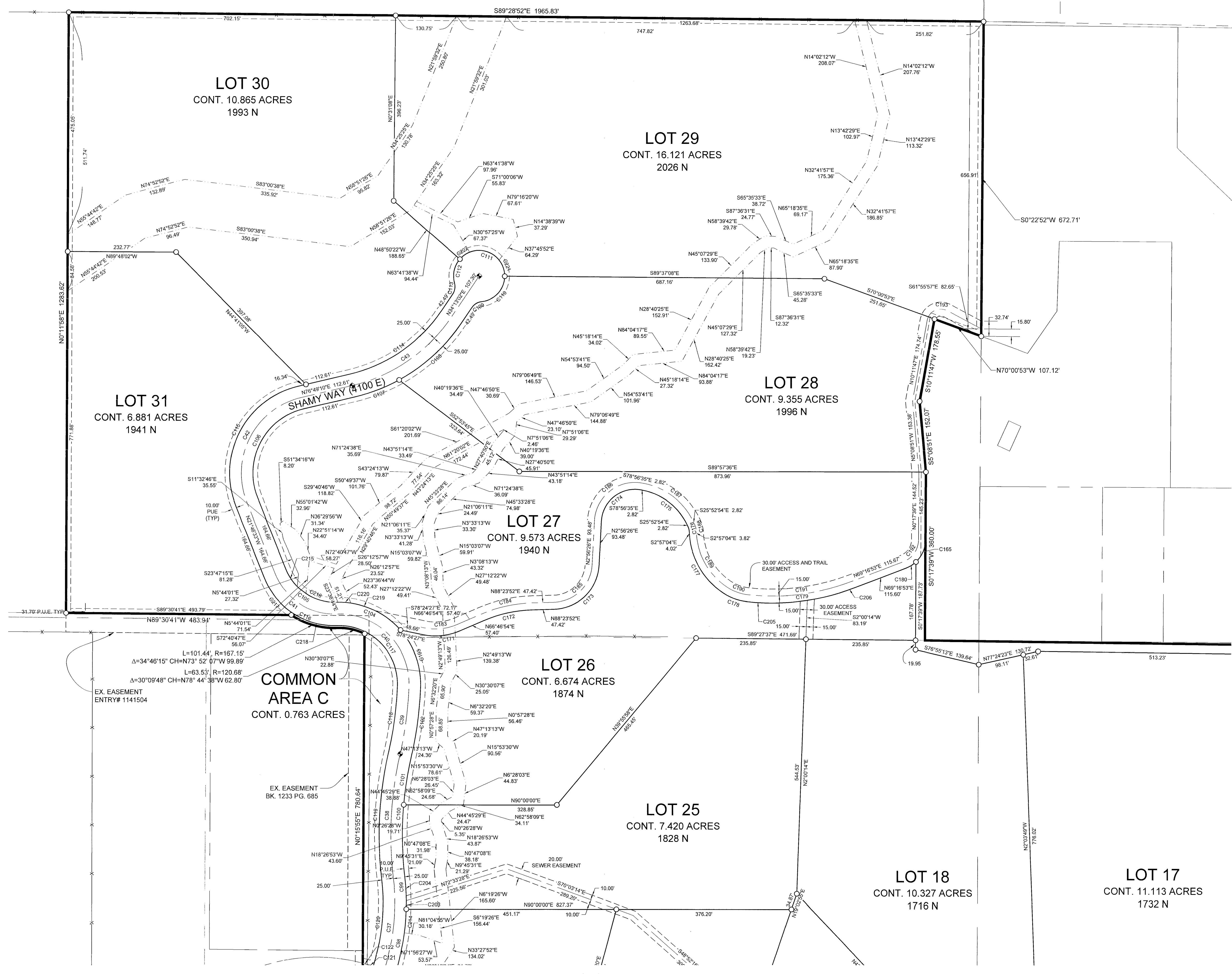

- LEGEND**
- WEBER COUNTY MONUMENT AS NOTED
 - SET 24" REBAR AND CAP MARKED GARDNER ENGINEERING
 - SUBDIVISION BOUNDARY
 - LOT LINE
 - ADJACENT PARCEL
 - SECTION LINE
 - EASEMENT
 - EXISTING FENCE LINE
 - DRAINAGE EASEMENT

RECEIVED
 OCT 25 2022
 BY: 1383

DEVELOPER: OSPREY RANCH LLC JOHN LEWIS 3718 NORTH WOLF CREEK DRIVE EDEN, UTAH, 84310 801-430-1507	S5 <hr/> 7	COUNTY RECORDER	
		ENTRY NO. _____ FEE PAID _____ FILED FOR AND RECORDED _____ AT _____ IN BOOK _____ OF OFFICIAL _____ RECORDS, PAGE _____ RECORDED _____ FOR _____ COUNTY RECORDER _____ BY: _____	CIVIL • LAND PLANNING MUNICIPAL • LAND SURVEYING 5150 SOUTH 375 EAST OGDEN, UT OFFICE: 801.476.0202 FAX: 801.476.0066

R:\1201 - LEWIS HOMES\1205 - OSPREY RANCH\SURVEY\OSPREY RANCH PHASE 1 PLAT REVISED LOTS BLOCK.DWG

OSPREY RANCH SUBDIVISION PHASE 1
 LOCATED IN THE SOUTHEAST QUARTER OF SECTION 33 TOWNSHIP 7 NORTH RANGE 1 EAST AND THE
 NORTH HALF OF SECTIONS 3, AND 4 OF TOWNSHIP 6 NORTH, RANGE 1 EAST, SALT LAKE BASE AND
 MERIDIAN, WEBER COUNTY, UTAH, OCTOBER 2022

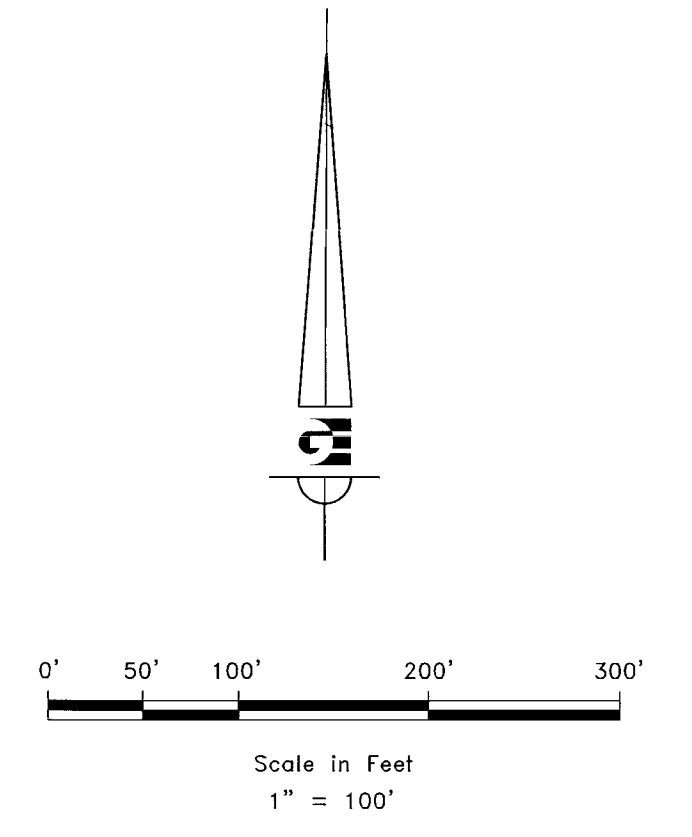
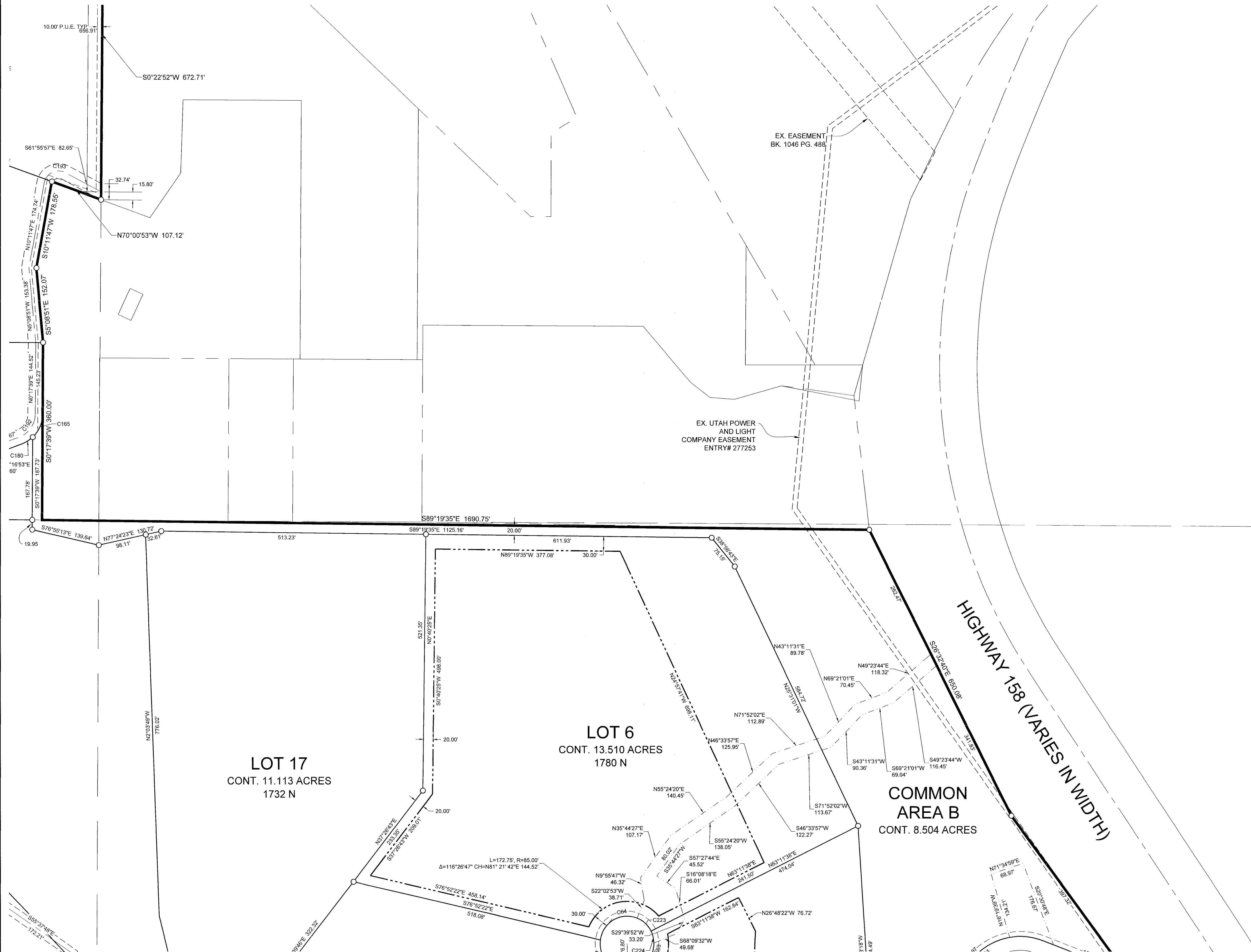

- LEGEND**
- ◆ WEBER COUNTY MONUMENT AS NOTED
 - SET 24" REBAR AND CAP MARKED GARDNER ENGINEERING
 - SUBDIVISION BOUNDARY
 - LOT LINE
 - - - ADJACENT PARCEL
 - - - SECTION LINE
 - - - EASEMENT
 - x - EXISTING FENCE LINE
 - - - BUILDABLE AREA SEE NOTE 4
 - - - DRAINAGE EASEMENT

RECEIVED
 OCT 25 2022
 BY: 1383

R:\2021-LEWIS HOMES\2105-OSPREY RANCH\SURVEY\DWG\OSPREY RANCH PHASE 1 PLAT REVISED LOTS BLOCK.DWG

DEVELOPER: OSPREY RANCH LLC JOHN LEWIS 3718 NORTH WOLF CREEK DRIVE EDEN, UTAH, 84310 801-430-1507	S6 <hr/> 7	COUNTY RECORDER ENTRY NO. _____ FEE PAID _____ FILED FOR AND RECORDED _____ AT _____ IN BOOK _____ OF OFFICIAL RECORDS, PAGE _____ RECORDED FOR _____ COUNTY RECORDER BY: _____
	<p>GARDNER ENGINEERING CIVIL • LAND PLANNING MUNICIPAL • LAND SURVEYING 5150 SOUTH 375 EAST OGDEN, UT OFFICE: 801.476.0202 FAX: 801.476.0066</p>	

