

PARCEL LINE DATA

SEGMENT	DIRECTION	LENGTH
L1	N89°10'36"W	28.04'
L2	N10°13'18"W	68.01'
L3	N10°13'18"W	17.83'
L4	N35°22'51"W	28.82'
L5	S68°02'40"W	34.58'
L6	S53°20'14"W	44.22'
L8	N80°47'37"E	51.86'
L9	N10°13'18"W	15.00'

PARCEL CURVE DATA

SEGMENT	LENGTH	RADIUS	DELTA	CHORD LENGTH	CHORD BEARING
C1	30.05'	233.00'	7°23'24"	30.03'	N06°31'36"W
C2	58.40'	133.00'	25°09'33"	57.93'	N22°48'05"W
C3	122.31'	237.70'	29°28'58"	120.97'	N64°04'36"E
C4	97.56'	252.70'	22°07'16"	96.96'	S67°48'53"W

ACCESS EASEMENT DESCRIPTION

AN ACCESS EASEMENT FOR INGRESS AND EGRESS SITUATED IN THE SOUTHEAST QUARTER OF SECTION 15, TOWNSHIP 5 NORTH, RANGE 1 WEST OF THE SALT LAKE BASE & MERIDIAN, WEBER COUNTY SURVEY. MORE PARTICULARLY DESCRIBED AS FOLLOWS:

BEGINNING AT A POINT LOCATED NORTH 00°35'07" EAST 1707.90 FEET ALONG THE WEST LINE OF SAID SOUTHEAST QUARTER AND SOUTH 89°24'53" EAST 88.90 FEET AND 116.48 FEET NORTH 80°47'37" EAST FROM THE SOUTHWEST CORNER OF SAID SOUTHEAST QUARTER;

RUNNING THENCE NORTH 80°47'37" EAST 51.86 FEET; THENCE SOUTH 53°20'14" WEST 44.22 FEET; THENCE SOUTH 68°02'40" WEST 34.58 FEET; THENCE SOUTHWESTERLY ON A NON-TANGENT CURVE TO THE RIGHT ALONG THE ARC OF A 252.70 FOOT RADIUS CURVE, A DISTANCE OF 97.56 FEET, CHORD BEARS SOUTH 67°48'53" WEST 96.96 FEET, HAVING A CENTRAL ANGLE OF 22°07'16" TO THE EAST RIGHT-OF-WAY LINE OF OLD POST ROAD; THENCE NORTH 10°13'18" WEST 15.00 FEET ALONG SAID EAST RIGHT-OF-WAY LINE; THENCE NORTHEASTERLY ON A NON-TANGENT CURVE TO THE LEFT ALONG THE ARC OF A 237.70 FOOT RADIUS CURVE, A DISTANCE OF 122.31 FEET, CHORD BEARS NORTH 64°04'36" EAST 120.97 FEET, HAVING A CENTRAL ANGLE OF 29°28'58" TO THE POINT OF BEGINNING.

PARCEL NO. 1 RECORD BOUNDARY DESCRIPTION

PART OF LOTS 1 AND 2, MARTIN ESTATES SUBDIVISION DESCRIBED AS FOLLOWS:

A PART OF THE SOUTHEAST QUARTER OF SECTION 15, TOWNSHIP 5 NORTH, RANGE 1 WEST OF THE SALT LAKE BASE AND MERIDIAN, WEBER COUNTY SURVEY:

BEGINNING AT A POINT LOCATED NORTH 00°35'07" EAST 1801.91 FEET ALONG THE WEST LINE OF SAID SOUTHEAST QUARTER AND SOUTH 89°24'53" EAST 45.64 FEET FROM THE SOUTHWEST CORNER OF SAID SOUTHEAST QUARTER, SAID POINT BEING ON THE EAST RIGHT OF WAY LINE OF THE OLD POST ROAD;

RUNNING THENCE NORTH 80°47'37" EAST 411.80 FEET TO THE WEST LINE OF SHADOW VALLEY ESTATES NO. 3; THENCE ALONG SAID WEST LINE SOUTH 00°28'23" EAST 100.92 FEET; THENCE SOUTH 80°42'30" WEST 167.48 FEET; THENCE SOUTH 80°47'37" WEST 202.36 FEET TO THE EAST RIGHT OF WAY LINE OF THE OLD POST ROAD; THENCE ALONG SAID EAST RIGHT OF WAY LINE THE FOLLOWING THREE (3) COURSES; (1) NORTH 10°13'18" WEST 17.83 FEET (2) TO THE LEFT ALONG THE ARC OF A 133.00 FOOT RADIUS CURVE A DISTANCE OF 58.40 FEET, CHORD BEARS NORTH 22°48'05" WEST 57.93 FEET (3) NORTH 35°22'51" WEST 28.82 FEET TO THE POINT OF BEGINNING.

CONTAINING 0.88 ACRES.

PARCEL NO. 2 RECORD BOUNDARY DESCRIPTION

PART OF LOT 2, MARTIN ESTATES SUBDIVISION DESCRIBED AS FOLLOWS:

A PART OF THE SOUTHEAST QUARTER OF SECTION 15, TOWNSHIP 5 NORTH, RANGE 1 WEST OF THE SALT LAKE BASE & MERIDIAN, WEBER COUNTY SURVEY.

BEGINNING AT A POINT LOCATED NORTH 00°35'07" EAST 1707.90 FEET ALONG THE WEST LINE OF SAID SOUTHEAST QUARTER AND SOUTH 89°24'53" EAST 88.90 FEET FROM THE SOUTHWEST CORNER OF SAID SOUTHEAST QUARTER, SAID POINT BEING ON THE EAST RIGHT OF WAY LINE OF THE OLD POST ROAD;

RUNNING THENCE NORTH 80°47'37" EAST 202.36 FEET; THENCE NORTH 80°42'30" EAST 167.48 FEET TO THE WEST LINE OF SHADOW VALLEY ESTATES NO. 3; THENCE ALONG SAID WEST LINE SOUTH 00°28'23" EAST 134.82 FEET; THENCE NORTH 89°05'29" WEST 177.91 FEET; THENCE SOUTH 80°21'26" WEST 146.81 FEET; THENCE NORTH 89°10'36" WEST 28.04 FEET TO THE EAST RIGHT OF WAY LINE OF THE OLD POST ROAD; THENCE ALONG SAID EAST LINE THE FOLLOWING TWO (2) COURSES: (1) TO THE LEFT ALONG THE ARC OF A 233.00 FOOT RADIUS CURVE A DISTANCE OF 30.05 FEET, CHORD BEARS NORTH 06°31'36" WEST 30.03 FEET; (2) NORTH 10°13'18" WEST 68.01 FEET TO THE POINT OF BEGINNING.

CONTAINING 0.91 ACRES.

NARRATIVE

THE PURPOSE OF THIS SURVEY WAS TO ESTABLISH AND SET THE PROPERTY CORNERS OF THE AMENDED SUBDIVISION AND TO WRITE A DESCRIPTION FOR AN ACCESS EASEMENT AS SHOWN AND DESCRIBED HEREON. THE SURVEY WAS ORDERED BY SHANNON RILEY. THE CONTROL USED TO ESTABLISH THE PROPERTY CORNERS WAS THE OFFICIAL PLAT OF MARTIN ESTATES SUBDIVISION, ENTRY NO. 1626915 ALONG WITH THE EXISTING WEBER COUNTY SURVEY MONUMENTATION SURROUNDING SECTION 15, T5N, R1W, SLB&M.

THE BASIS OF BEARING IS THE WEST LINE OF THE SOUTHEAST QUARTER OF SAID SECTION WHICH BEARS NORTH 0°35'07" EAST, UTAH NORTH, STATE PLANE, CALCULATED N.A.D.83 BEARING.

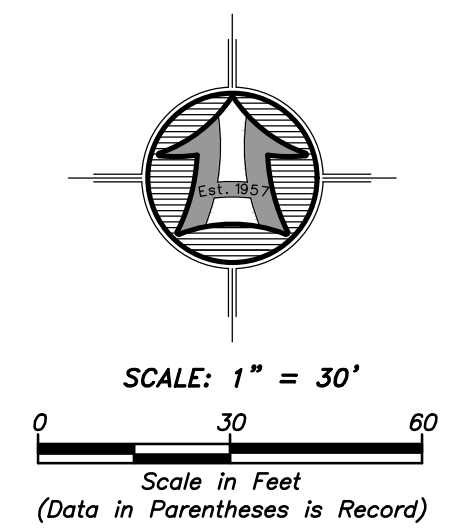

LEGEND

	SUBJECT PROPERTY LINE
	ADJOINING PROPERTY LINE
	CENTERLINE
	EASEMENT
	FOUND REBAR SET BY OTHERS
	SET 5/8"x24" REBAR WITH CAP
	SECTION CORNER

SURVEYOR'S CERTIFICATE

I, ROGER C. SLADE, DO HEREBY CERTIFY THAT I AM A REGISTERED PROFESSIONAL LAND SURVEYOR IN THE STATE OF UTAH IN ACCORDANCE WITH TITLE 58, CHAPTER 22, PROFESSIONAL ENGINEERS AND PROFESSIONAL LAND SURVEYORS ACT; AND BY THE AUTHORITY OF THE OWNERS, I HAVE COMPLETED A SURVEY OF THE PROPERTY DESCRIBED AND SHOWN HEREON THIS PLAT IN ACCORDANCE WITH SECTION 17-23-17 AND HAVE VERIFIED ALL MEASUREMENTS, AND THAT THE SAME HAS BEEN SURVEYED AND MONUMENTS HAVE BEEN LOCATED AND/OR PLACED ON THE GROUND AS REPRESENTED ON THE PLAT HEREON.

SIGNED THIS 16TH DAY OF AUGUST, 2024.

ROGER C. SLADE, PLS
UTAH LAND SURVEYOR LICENSE NO. 11386802

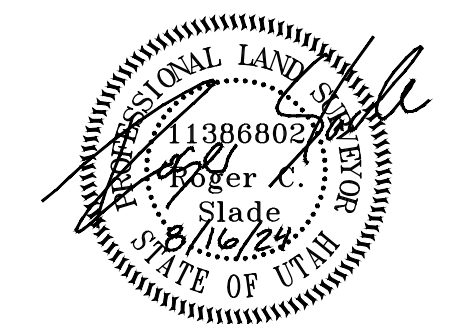

RECEIVED
AUG 20 2024
FILE # 7872

HANSEN & ASSOCIATES, INC.
Consulting Engineers and Land Surveyors
538 North Main Street, Brigham, Utah 84302
Visit us at www.hailes.net
Logan Ogden
(435) 723-3491 (801) 399-4905 (435) 952-8272
Celebrating over 68 Years of Business

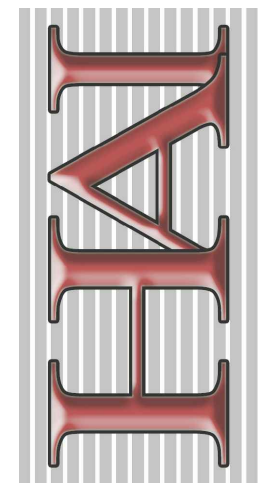

Drawn By: RS Date: 08/15/2024
Designed By: JRP
Checked By: JRP
Approved By: JRP
Scale: 1" = 30'
Drawing File: 24-3-141v18_R05.dwg
JOB NUMBER: 24-3-141

LOT LINE AMENDMENT SURVEY FOR
SHANNON RILEY
5366 NORTH OLD POST ROAD
WEBER COUNTY, UTAH
A PART OF THE SOUTHEAST QUARTER OF SECTION 15,
TOWNSHIP 5 NORTH, RANGE 1 WEST, S.L.B.&M.