

THE VILLAGE AT WOLF CREEK 1ST AMENDMENT
(ENTRY NO. 2991526)

PARCEL CURVE DATA

SEGMENT	LENGTH	RADIUS	DELTA	CHORD LENGTH	CHORD BEARING
C1	59.64'	210.00'	16°16'22"	59.44'	N05°12'32"W
C2	5.79'	210.00'	1°34'48"	5.79'	N03°43'03"E
C3	44.47'	391.34'	6°30'40"	44.45'	N01°15'07"E
C4	77.29'	391.34'	11°18'55"	77.16'	N07°39'40"W

PARCEL LINE DATA

SEGMENT	DIRECTION	LENGTH
L1	N79°30'30"E	45.96'
L2	S02°16'39"E	3.61'
L3	S18°50'18"E	38.43'
L4	S12°23'42"E	4.04'
L5	S66°02'53"W	58.23'
L6	N71°09'52"E	27.50'
L7	N79°30'29"E	8.55'
L8	S14°18'32"E	35.47'
L9	S11°53'57"E	26.63'
L10	S09°00'21"E	19.69'
L11	S80°22'49"W	42.08'

AS SURVEYED BOUNDARY DESCRIPTION
ALL OF LOT 33 AND LOT 35, THE VILLAGE AT WOLF CREEK P.U.D. SUBDIVISION, ENTRY NO. 1841069, WEBER COUNTY, UTAH, ACCORDING TO THE OFFICIAL PLAT THEREOF.

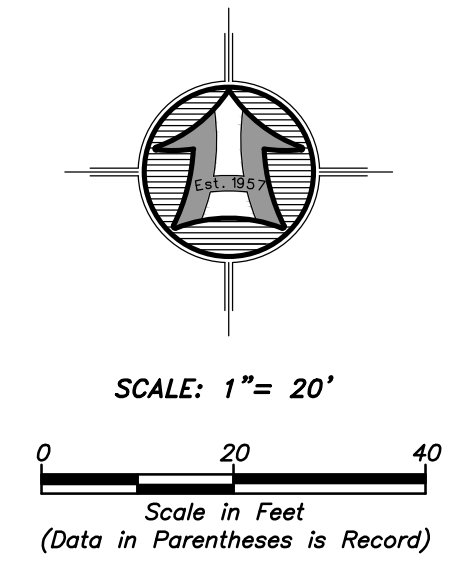

LEGEND

	SUBJECT PROPERTY LINE
	ADJOINING PROPERTY LINE
	PREVIOUS PROPERTY LINE
	CENTERLINE
	FENCE LINE
	STREET MONUMENT
	FOUND REBAR SET BY OTHERS
	SET 5/8"x24" REBAR WITH CAP
	SECTION CORNER

RECEIVED
DEC 11 2024
FILE # 7942

NARRATIVE

THE PURPOSE OF THIS SURVEY WAS TO ESTABLISH AND SET THE PROPERTY CORNERS OF THE PARCELS AS SHOWN AND DESCRIBED HEREON. THE SURVEY WAS ORDERED BY ANDREW PYNES. THE CONTROL USED TO ESTABLISH THE PROPERTY CORNERS WAS THE VILLAGE AT WOLF CREEK P.U.D., ENTRY NO. 1841069, AND THE EXISTING WEBER COUNTY SURVEY MONUMENTATION SURROUNDING SECTION 22, T7N, R1E, SLB&M.

THE BASIS OF BEARING IS THE SOUTH LINE OF THE SOUTHWEST QUARTER OF SAID SECTION WHICH BEARS SOUTH 89°07'34" EAST, ASSUMED BEARING AS SHOWN ON THE THE VILLAGE AT WOLF CREEK P.U.D. SUBDIVISION.

SURVEYOR'S CERTIFICATE

I, MATT PRETL DO HEREBY CERTIFY THAT I AM A REGISTERED PROFESSIONAL LAND SURVEYOR IN THE STATE OF UTAH IN ACCORDANCE WITH TITLE 58, CHAPTER 22, PROFESSIONAL ENGINEERS AND PROFESSIONAL LAND SURVEYORS ACT; AND BY THE AUTHORITY OF THE OWNERS, I HAVE COMPLETED A SURVEY OF THE PROPERTY DESCRIBED AND SHOWN HEREON THIS PLAT IN ACCORDANCE WITH SECTION 17-23-17 AND HAVE VERIFIED ALL MEASUREMENTS, AND THAT THE SAME HAS BEEN SURVEYED AND MONUMENTS HAVE BEEN LOCATED AND/OR PLACED ON THE GROUND AS REPRESENTED ON THE PLAT HEREON.

SIGNED THIS 4TH DAY OF NOVEMBER, 2024.

MATT PRETL, PLS
UTAH LAND SURVEYOR LICENSE NO. 10437995



HANSEN & ASSOCIATES, INC.
Consulting Engineers and Land Surveyors
538 North Main Street, Brigham, Utah 84302
Visit us at www.hales.net
Brigham City, Ogden
(435) 723-4491 (801) 399-4905 (435) 752-8272
Celebrating over 66 Years of Business

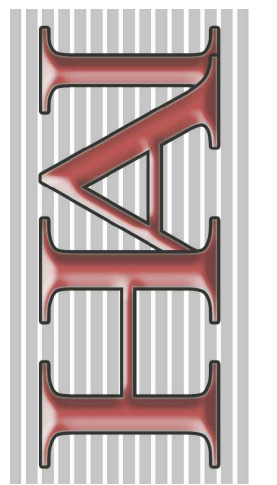

Drawn By: MP Date: 11/14/2024
Designed By: ES
Checked By: ES
Approved By: ES
Scale: 1" = 20'
Drawing File: 24-3-212x19
JOB NUMBER: 24-3-212

PROPERTY SURVEY FOR
ANDREW PYNES
+/- 3570 N 4875 E
EDEN, WEBER COUNTY, UTAH
A PART OF THE SOUTHWEST QUARTER OF SECTION 22
TOWNSHIP 7 NORTH, RANGE 1 EAST, SLB&M.